

---

**U.S. ARMY MEDICAL DEPARTMENT CENTER AND SCHOOL  
FORT SAM HOUSTON, TEXAS 78234-6100**

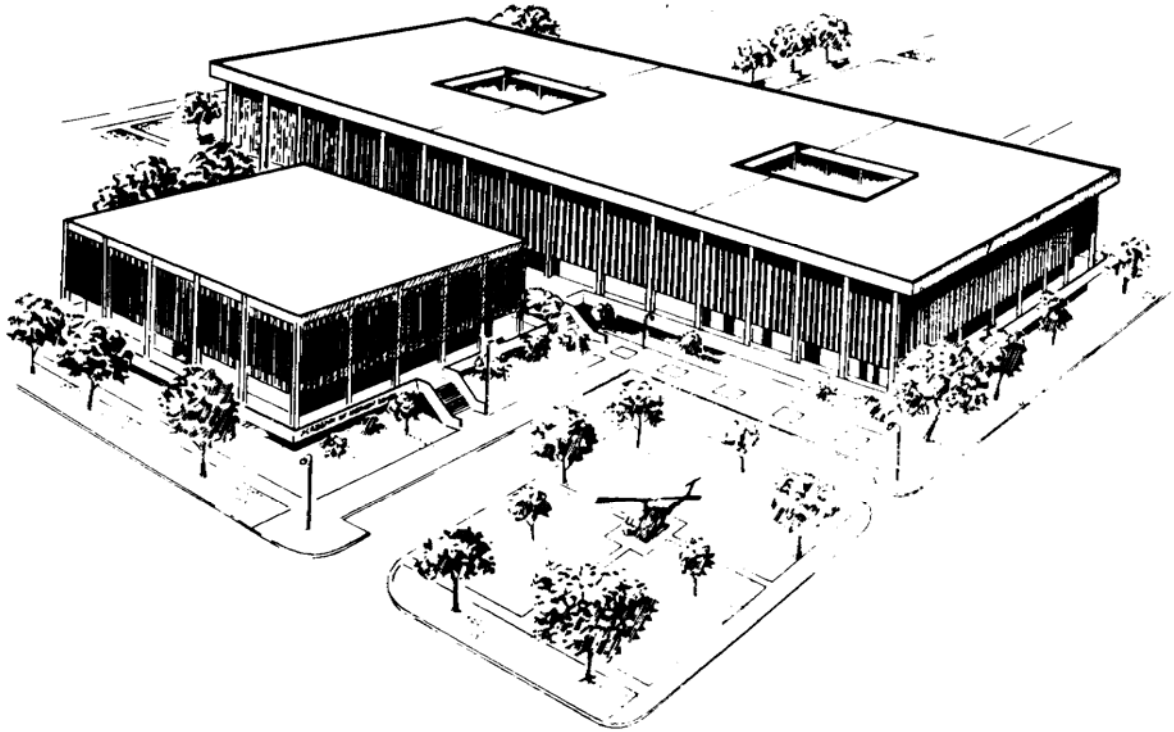

# **INTRODUCTION TO MILITARY PREVENTIVE MEDICINE**

**SUBCOURSE MD0008**

**EDITION 100**

## **DEVELOPMENT**

This subcourse is approved for resident and correspondence course instruction. It reflects the current thought of the Academy of Health Sciences and conforms to printed Department of the Army doctrine as closely as currently possible. Development and progress render such doctrine continuously subject to change.

## **ADMINISTRATION**

For comments or questions regarding enrollment, student records, or shipments, contact the Nonresident Instruction Branch at DSN 471-5877, commercial (210) 221-5877, toll-free 1-800-344-2380; fax: 210-221-4012 or DSN 471-4012, e-mail [accp@amedd.army.mil](mailto:accp@amedd.army.mil), or write to:

COMMANDER  
AMEDDC&S  
ATTN MCCS HSN  
2105 11TH STREET SUITE 4192  
FORT SAM HOUSTON TX 78234-5064

Approved students whose enrollments remain in good standing may apply to the Nonresident Instruction Branch for subsequent courses by telephone, letter, or e-mail.

Be sure your social security number is on all correspondence sent to the Academy of Health Sciences.

## **CLARIFICATION OF TRAINING LITERATURE TERMINOLOGY**

When used in this publication, words such as "he," "him," "his," and "men" are intended to include both the masculine and feminine genders, unless specifically stated otherwise or when obvious in context.

.

## TABLE OF CONTENTS

| Lesson        |  | Paragraphs        |
|---------------|--|-------------------|
|               | <b>INTRODUCTION</b>  |                   |
| 1             | IMPORTANCE AND SCOPE OF MILITARY PREVENTIVE MEDICINE               | 1-1--1-21         |
|               | Exercises  |                   |
| 2             | THE ARMY IMMUNIZATION PROGRAM                                      | 2-1--2-7          |
|               | Exercises  |                   |
| 3             | FIELD FORCES/FIXED INSTALLATION                                    |                   |
|               | Section I. Medical Threat to Field Forces                          | 3-1--3-8          |
|               | Section II. Preventive Medicine Activities in Fixed Installations  | 3-9--3-10         |
|               | Exercises  |                   |
| 4             | CLIMATIC INJURY CONTROL  |                   |
|               | Section I. Environmental Cold Injuries                             | 4-1--4-8          |
|               | Section II. Environmental Heat Injuries                            | 4-9--4-24         |
|               | Exercises  |                   |
| 5             | MEDICAL ASPECTS OF WATER SUPPLY                                    |                   |
|               | Section I. Introduction  | 5-1--5-5          |
|               | Section II. Principles of Water Purification                       | 5-6--5-10         |
|               | Section III. Quartermaster Water Treatment                         | 5-11--5-15        |
|               | Exercises  |                   |
| 6             | FIELD WATER SUPPLY AND WASTE DISPOSAL                              |                   |
|               | Section I. Individual and Unit Water Supply and Purification       | 6-1--6-5          |
|               | Section II. Field Waste Disposal                                   | 6-6--6-22         |
|               | Section III. Field Sanitary Devices                                | 6-23--6-35        |
|               | Exercises  |                   |
| <u>Lesson</u> |  | <u>Paragraphs</u> |
| 7             | MILITARY MEDICAL ENTOMOLOGY FIELD CONTROL                          | 7-1--7-20         |
|               | Exercises  |                   |
| 8             | SEXUALLY TRANSMITTED DISEASES                                      |                   |
|               | Section I. The Army's Sexually Transmitted Disease Control Program | 8-1--8-2          |
|               | Section II. The Epidemiology of Sexually Transmitted Diseases      | 8-3--8-6          |
|               | Section III. Other Sexually Transmitted Diseases                   | 8-7--8-14         |
|               | Exercises  |                   |

**CORRESPONDENCE COURSE OF  
THE ACADEMY OF HEALTH SCIENCES, UNITED STATES ARMY**

**SUBCOURSE MD0008**

**INTRODUCTION TO MILITARY PREVENTIVE MEDICINE**

**INTRODUCTION**

The motto of the Army Medical Department "to conserve the fighting strength" aptly summarizes in one phrase the mission of all components of AMEDD and the major objective of military preventive medicine. Military history is replete with examples which emphasize the importance of preventing disease and noncombat injury as the principal means of conserving the fighting strength. Today, preventive medicine encompasses the broad spectrum of activities including disease control, occupational health, environmental quality and food service sanitation.

Preventive medicine as a military specialty originated around the turn of the century from the young science of bacteriology and with the painful experiences of the communicable disease pandemic during the Spanish-American War. The specialty as a whole matured greatly during World War I. During World War II, preventive medicine was severely tested, inasmuch as the Armed Forces were confronted with the varied problems of preventing disease on a global basis. Full recognition was accorded the field as a medical specialty when the Medical Specialty Board of Preventive Medicine and Public Health was established in 1949.

Today, military preventive medicine remains a most powerful weapon against disease and trauma. Environmental hazards have posed a threat to man since the beginning of his existence. Communicable disease has not been conquered; it is only being contained or held at bay. Thus, it behooves everyone to equip himself with a working knowledge of health and environment principles, methods, and practices. Such knowledge will help you, as a member of the Army Medical Department, to survive, to perform your assignment, and to help others.

This subcourse is designed to give you a general introduction to military preventive medicine with particular emphasis on water supply and waste disposal, climate injury and disease control!

**Subcourse Components:**

The subcourse instructional material consists of the following:

- Lesson 1, Introduction to Military Preventive Medicine.
- Lesson 2, The Army Immunization Program.
- Lesson 3, Field Forces/Fixed Installations.
- Lesson 4, Climatic Injury Control.
- Lesson 5, Medical Aspects of Water Supply.
- Lesson 6, Field Water Supply and Waste Disposal.
- Lesson 7, Military Medical Entomology Field Control.
- Lesson 8, Sexually Transmitted Diseases

### **Study Suggestions:**

Here are some suggestions that may be helpful to you in completing this subcourse:

- Read and study each lesson carefully.
- Complete the subcourse lesson by lesson. After completing each lesson, work the exercises at the end of the lesson, marking your answers in this booklet.

- After completing each set of lesson exercises, compare your answers with those on the solution sheet that follows the exercises. If you have answered an exercise incorrectly, check the reference cited after the answer on the solution sheet to determine why your response was not the correct one.

### **Credit Awarded:**

To receive credit hours, you must be officially enrolled and complete an examination furnished by the Nonresident Instruction Branch at Fort Sam Houston, Texas. Upon successful completion of the examination for this subcourse, you will be awarded 14 credit hours.

You can enroll by going to the web site <http://atrrs.army.mil> and enrolling under "Self Development" (School Code 555).

A listing of correspondence courses and subcourses available through the Nonresident Instruction Section is found in Chapter 4 of DA Pamphlet 350-59, Army Correspondence Course Program Catalog. The DA PAM is available at the following website: <http://www.usapa.army.mil/pdffiles/p350-59.pdf>.

## **LESSON ASSIGNMENT**

|                          |  |
|--------------------------|--|
| <b>LESSON 1</b>          | Importance and Scope of Military Preventive Medicine.  |
| <b>LESSON ASSIGNMENT</b> | Paragraphs 1-1 through 1-21.   |
| <b>LESSON OBJECTIVES</b> | <p>After completing this lesson, you should be able to:</p> <ol style="list-style-type: none"><li>1-1. Identify the major disease problems encountered by military units both in the field and fixed installations.</li><li>1-2. Identify the AMEDD preventive medicine resources in support of troops in combat and in fixed installations.</li></ol> |
| <b>SUGGESTION</b>        | After completing the assignment, complete the exercises at the end of this lesson. These exercises will help you to achieve the lesson objectives.   |

## LESSON 1

### IMPORTANCE AND SCOPE OF MILITARY PREVENTIVE MEDICINE

#### 1-1. BACKGROUND

a. Since earliest recorded history, military leaders have been aware of the devastating effects of diseases upon troops. Around 400 BC, Susruta, an Indian physician, wrote: "All common practice of the enemy under such circumstances is to poison the wells on the roadside, the articles of food, the shade of trees (shadowy places), and the field and forage for cattle. Hence, it is incumbent on a physician marching with troops to inspect, examine, and purify these before using any of them in case they be poisoned." Later, around AD 400, Vegetius, a Roman leader, wrote: "large bodies of troops should not camp too long in any one place, since epidemic disease can arise from corruption of the air and water and can only be prevented by frequent change of camp. Troops should not camp upon dry hillsides devoid of shade and in summer should always be provide with tents. One drink of polluted water may be as potent as poison in starting an epidemic. In periods of great heat, all marching should be done before sunrise. In winter, little can be expected of the soldier if he is allowed to freeze. It is the duty of the commanding officer to provide good water, proper food, and medical attention for the sick." The responsibility of the commander to provide these essentials is still recognized and emphasized today.

b. Some of the greatest fiascos in military history have been the result of a breakdown in hygiene and disease control. For example, when Napoleon Bonaparte sent a force of 22,000 men to suppress a rebellion in the French colony of Haiti in 1803, 20,000 men died from yellow fever. Subsequently, Haiti achieved independence with little French opposition. Again in 1813, Napoleon invaded Russia with an Army of 480,000. Although he succeeded in taking Moscow, his troops were decimated by guerrillas disease, and cold injury, forcing his retreat. Only 10,000 men returned to France. Of the 470,000 men who were lost, only 60,000 were killed in action; the remainder died of disease and cold injury.

c. The American experience has not been greatly different. During the Civil War, twice as many men in both the Union and Confederate armies died from disease as from enemy-inflicted wounds. During the Cuban campaign of the Spanish-American War, the ravages of yellow fever and other diseases accounted for five deaths for every combat death. During World War I, for the first time in history, the ratio of deaths from disease to deaths from combat causes was reduced to 1:1. Although disease is not longer the major cause of death in combat, it is still responsible for an overwhelming majority of the hospital admissions and continues to be a major problem.

## 1-2. EFFECTS OF DISEASES UPON TROOPS

a. When one speaks of Military Preventive Medicine, it is traditional to give examples of battles, wars, and nations that have been lost because of epidemics. One of the best examples is that of Napoleon's Grand Army which marched into Russia with 480,000 men and retreated back to Paris with only 10,000. Of the 470,000 that did not make it back only 60,000 fell from combat causes. The remaining 410,000 succumbed to disease. Cold injury, caused by the severe Russian winter, accounted for many and a disease called epidemic (louse-borne) typhus accounted for even more. Prior to World War I, the leading cause of death among military troops during wartime was disease.

b. History shows that disease and injury as military problems are factors for which the military leader must plan. In Table 1, the periods of war listed were ones in which combat was the heaviest. In spite of these concentrated fighting periods, hospital admissions for disease and nonbattle injury far exceeded admissions because of hostile action of the enemy. Furthermore, experience reveals that hospital admissions for disease usually exceed hospital admissions for nonbattle injury and battle injury combined. For example, of the 81.8 percent hospital admissions for disease and noncombat injury in Vietnam in 1969, only 13.7 percent were for nonbattle injury and 68.1 percent were for disease.

| <b>WAR PERIOD AND LOCATION</b>  | <b>DISEASE AND NONCOMBAT INJURY</b> | <b>BATTLE INJURY</b> |
|---|-------------------------------------|----------------------|
| World War II<br>November 1942 to August 1945<br>Pacific Theater of Operations | 95%                                 | 5%                   |
| World War II<br>June 1944 to May 1945<br>European Theater of Operations       | 77%                                 | 23%                  |
| Korean War<br>July 1950 to July 1953  | 83%                                 | 17%                  |
| Vietnam War<br>1 January 1969 to 31 December 1969                             | 81.8%                               | 18.2%                |

Table 1-1. Percentage of United States Army (US Army) hospital admissions during selected war periods.

## 1-3. RESPONSIBILITIES FOR HEALTH

a. The commander of a military organization is responsible for the health of his command. In the fulfillment of this responsibility, he is assisted by a staff of trained specialists. The surgeon, who is the chief medical advisor to the commander, provides technical medical advice and is responsible for the successful functioning of the medical service within the command.



b. Military medicine is an active part of the machinery of war. Unless military medicine is thoroughly integrated into military plans and operations, unnecessary costs in manpower and in time loss may be the price paid to meet objectives. This is starkly illustrated by the situation existing in the occupation of Lebanon by US troops in 1958. Preventive medicine units were phased in 3 weeks late; no provision was made for the procurement of unskilled labor to help control arthropod-borne disease. Insecticides accompanying the units were not satisfactory because of the high degree of resistance to DDT insecticide that had developed in the local insect populations. Until commanders neglected enforcement of the most elementary principles of basic sanitation, the hospital admissions because of diarrhea and dysentery reached astronomical level of 3,650 per 1,000 men per year.

c. If health responsibilities are to be met, command must understand military medicine and the implication of disease and injury, and Army Medical Department (AMMED) personnel must be acquainted with military theory and practice. Mutual effort is fundamental if planning and operations are to be successful.

d. The commander employs the troops to fulfill his mission; however, he requires troops in good health. His plans and decisions are based in part on information he receives concerning the health of the command and on recommendations of AMEDD personnel.

e. The military mission of a command is all-important; all preventive medicine measures for the command must be formulated with this in mind. (It is more reasonable to prevent disease than to treat it, but when troops are training for or engaged in combat, health measures which interfere with military activity more than the condition which they are designed to correct are not feasible.) Mass scale disease control measures must be practicable, simple, and capable of being performed in a short period of time.

f. Within the military, there are two main types of preventive medicine. Garrison preventive medicine involves activities similar to those of a local health department. Field preventive medicine is unique to the military. It involves prevention of disease in combat situations.

#### **1-4. GARRISON PREVENTIVE MEDICINE**

a. Just as cities, counties, and states have public health departments, military installations have preventive medicine activities. One of these is to gather monthly statistics concerning venereal disease incidence. These preventive medicine activities have seven major program areas for which they are responsible:

- (1) Infectious disease control.
- (2) Environmental sanitation.

- (3) Radiation and chemical protection.
- (4) Community health nurse.
- (5) Occupational health.
- (6) Hospital acquired infection control.
- (7) Medical entomology.

b. Infectious disease control-preventive Medicare personnel ensure that troops receive the proper immunizations. Immunization increases the resistance individuals have against disease. It also reduces an individual's exposure to a disease since many other persons are also immunized. There are few diseases for which immunizations are available. For the other diseases, control involves finding cases and investigating them quickly. There are specific programs to deal with sexually transmitted diseases and tuberculosis.

#### **1-5. ENVIRONMENTAL SOLUTION**

The Preventive Medicine Activity inspects dining facilities, cafeterias, trucks of local vendors, and any other establishment serving food on post. Preventive Medicine also ensures that the installation water supply is potable through periodic monitoring. Wastewater and solid waste disposal are also monitored by Preventive Medicine. In accordance with AR 40-5, Preventive Medicine also inspects day care centers, barber shops, and beauty shops, for sanitary deficiencies.

#### **1-6. RADIATION AND CHEMICAL PROTECTION**

The large ionizing radiation hazards on most fixed installations are in the diagnostic and therapeutic radiology departments of the hospitals. Preventive medicine monitors these hazards. In addition, other potential hazards exist such as microwave ovens in Food Service Facilities.

#### **1-7. COMMUNITY HEALTH NURSING**

Most installations have at least one community health nurse who fulfills a variety of roles. The community health nurse provides services primarily to service members' families. Services include:

- a. Prenatal Programs--usually run in cooperation with the OB-GYN department.
- b. Well Baby Clinic--usually run in cooperation with the pediatric department.
- c. All other areas of health education.

- d. Prevention and identification of abuse within families.
- e. Maintenance of the tuberculosis registry.

## **1-8. OCCUPATIONAL HEALTH**

Each preventive medicine activity maintains a Local Health Hazard Inventory (LOHHI). The LOHHI identifies job-related chemical or physical hazards for military and civilian personnel. This information is then used to plan specific medical surveillance for those personnel potentially exposed to job related hazards. Hearing and vision monitoring are done routinely for all personnel. Note that active duty personnel are covered under the Occupational Safety and Health Act (OSHA) except in times of national emergency.

## **1-9. HOSPITAL ACQUIRED INFECTION CONTROL**

Hospital acquired infections are a significant burden on the military in both financial loss and personnel loss. Approximately three percent of all admissions stay an extra 7-10 days because of hospital acquired infections. Each hospital has an infection control committee and an infection control program to prevent or control hospital-acquired infections. Additionally, the Surgeon General of the Army has mandated that medical treatment facilities (MTF) in the continental US will be accredited by the Joint Commission for the Accreditation of Hospitals (JCAH). The JCAH requires that a hospital have an ongoing hospital wide infection control program for both inpatient and outpatient services.

## **1-10. MEDICAL ENTOMOLOGY**

Preventive medicine is responsible for control and surveillance of medically important arthropods such as mosquitoes, ticks, and flies and for control of rodents.

## **1-11. FIELD PREVENTIVE MEDICINE**

It is impossible in a tactical situation for preventive medicine to function in the same manner as in a garrison situation. Thus emphasis in the field is on those preventive measures which will have the greatest impact on lowering disease or injury. The major causes of health problems to a force in the field are food and water-borne disease, arthropod-borne disease, heat-related injury, and cold related injury. Countermeasures against these threats will be discussed later in the subcourse.

## **1-12. GROUPS OF COMMUNICABLE DISEASES**

For convenience, communicable diseases may be classified into five groups: respiratory, intestinal, arthropod-borne, venereal, and miscellaneous. Some of the diseases in these groups are transmitted by water and are classed as waterborne diseases. A disease may be classified in more than one way. In this text, diseases are classified according to manner of transmission or spread and type of control measure needed to prevent their spread.

a. **Respiratory Diseases.** These are usually transmitted from person to person by discharges (spray, cough, sneeze, breath) from the nose, mouth, throat, or lungs of an infected individual. Examples: common cold, pneumonia, sore throat, and tuberculosis.

b. **Intestinal Diseases.** Usually transmitted by food and water that has become contaminated with feces or urine from an infected human or animal. Examples: typhoid, and paratyphoid fevers, dysentery, and cholera.

c. **Arthropod-borne Diseases.** Transmitted from person to person (or from animal to person) by arthropods. Examples: malaria, typhus, and yellow fever.

d. **Venereal Diseases.** Transmitted from person to person by sexual intercourse. Examples: Syphilis, gonorrhea, and chancroid.

e. **Miscellaneous Diseases.** Those communicable diseases that do not fall conveniently into any of the above groups. Examples: tetanus (lockjaw), scabies (the "itch"), rabies (hydrophobia), and dermatophytosis (athlete's foot).

### 1-13. ESSENTIALS FOR THE TRANSMISSION OF DISEASE

Each case of communicable disease represents steps in a series of events that may lead to a new case of disease. Each step in this series is dependent on the successful completion of the preceding step to form a link in the chain of the spread of infection. The three links in this chain are (1) the reservoir (source), (2) the vehicle (means of transmission), and (3) the susceptible person, figure 1-1. If any of the links in this chain can be broken, disease will not result. Personal hygiene will help break all three links in the chain of infection, figure 1-2.

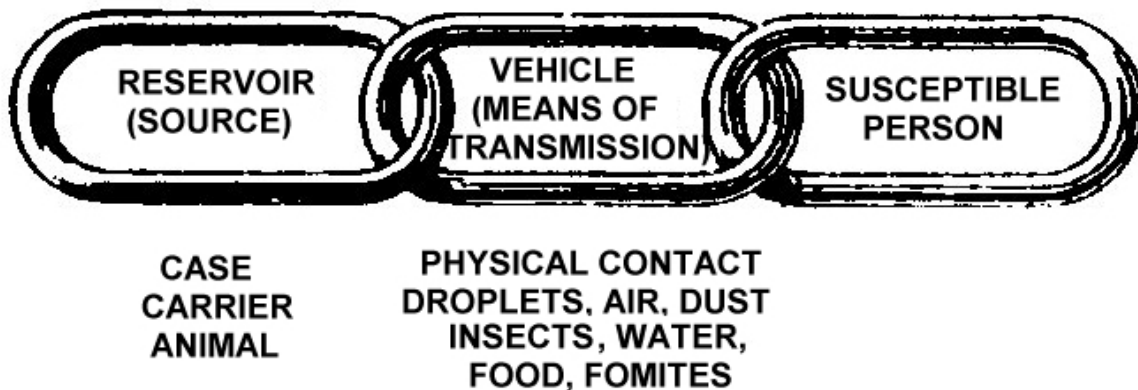

Figure 1-1. The chain of disease transmission.

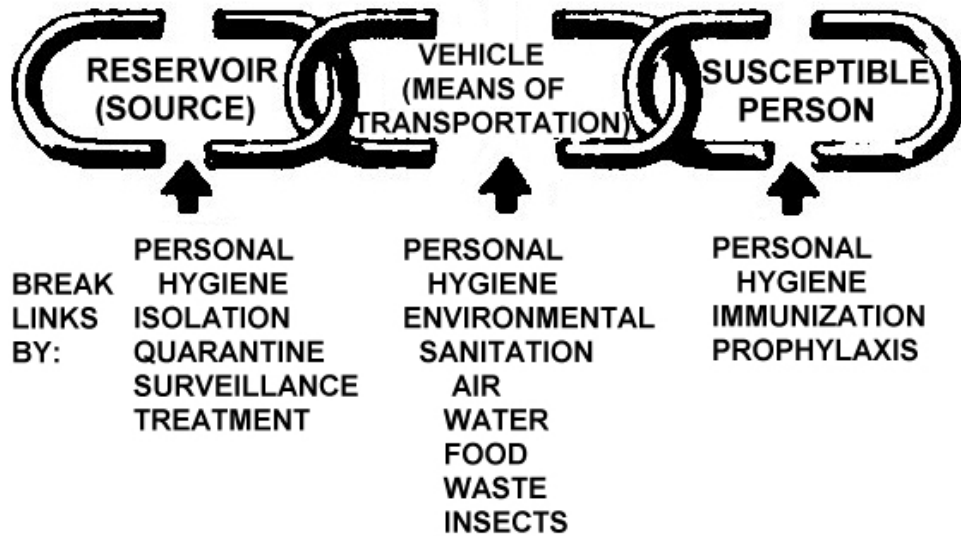

Figure 1-2. Break in the chain of disease transmission.

#### 1-14. SOURCE OF DISEASE (RESERVOIR)

The source of disease (infection) may be a case, a carrier, or an animal.

a. **Case.** A person who is actually ill with a disease is called a case. A case is a common source of infection.

b. **Carrier.** A person who harbors disease organisms, but who is not ill is called a carrier. This person can spread the germs in the same manner as does the case and is actually more dangerous, because he may not know that he is harboring the infectious germs.

c. **Animals.** Animals, especially rodents, are reservoirs for certain diseases that also affect humans. The animal reservoirs may be sick, or they may harbor the disease in much the same way as a human carrier. The term animal means any member of the animal kingdom, thus including insects as well as mammals.

#### 1-15. METHODS OF TRANSMISSION (VEHICLES)

Diseases may be transmitted either by direct or indirect methods.

a. **Direct Transmission.** Direct transmission is a method of transmission in which the infectious organisms pass directly from one person to another. It may happen in either of the following ways:

(1) Physical contact. Certain diseases are spread by physical contact with an infected individual. Examples are syphilis, gonorrhea, and scabies.

(2) Droplet. This method of disease transmission occurs when persons are so close together that droplets which are spread in coughing, sneezing, or even talking are picked up by susceptible persons. Respiratory diseases are spread in this manner.

b. **Indirect Transmission.** Indirect transmission is the transfer of infection without close contact between the source and the susceptible person.

(1) Arthropods. Flies, fleas, mosquitoes, and lice are among the insects (properly called arthropods) that spread disease from man to man or from animal to man. Such insects and related forms of life are called disease vectors. They pick up the disease germs by coming in contact with filth or by biting an infected person or animal. The insects may then transfer these germs to food, deposit them on a human body, or inject them into a human body by bite.

**NOTE:** In some instances, arthropods can be involved in direct transmission of disease. A mosquito, for example, can pick up disease germs when it bites a person sick with malaria. Later, the mosquito bites a susceptible person. The mosquito is therefore the vehicle by which disease is transmitted from one person to another.

(2) Water and food. Most of the diseases that are transmitted by water and food result from the water or food having become contaminated by feces, urine, or other infectious material from a case or carrier. If water or food is so contaminated and is then not properly treated, disease agents in the material may infect the consumer. Outbreaks of disease will occur where the practices of personal hygiene, sanitary principles of food handling, water purification, waste disposal, and control of flies and other vermin are not properly observed and enforced. Among the intestinal diseases usually transmitted by contaminated food or water are typhoid fever, infectious hepatitis, dysentery, cholera, and food poisoning.

(3) Air. Some of the organisms that are expelled from the respiratory tract of an infected individual are extremely small and light in weight. They may remain suspended in the air for hours. If they settle out, they may be thrown back into the air and resuspended in the dust. Inhalation of these living organisms by a susceptible individual can result in disease. Many of the respiratory diseases are transmitted in this manner.

(4) Fomites. Fomites are objects that may become contaminated with disease germs from an infected individual. They may become vehicles of disease transmission if a susceptible person uses them. Clothing, bed linen, and eating utensils are examples.

## 1-16. SUSCEPTIBLE INDIVIDUAL

A "susceptible" or "nonimmune" is a person who has little resistance against a particular organism and who, if exposed to this organism, is likely to contract disease.

By contrast, an "immune" is a person who has a high degree of resistance to the organism and who, when exposed, does not develop the disease.

## 1-17. IMMUNITY

Immunity may be defined as the ability of an individual to resist or overcome the invasion of disease germs. Most persons are born with a high level of immunity against certain disease germs, but this immunity is only temporary and is lost within a few months after birth. The immunity that adults possess usually is acquired after birth in one of the following ways.

a. **Natural Immunity.** A person may acquire immunity to certain diseases, such as measles, mumps, diphtheria, and chicken pox, by becoming infected with the germs that cause them. Such an infection may result in a typical case or it may be so mild that the disease is not recognized. In either instance, the body may build up resistance enough to keep the individual from contracting the disease again. Many other diseases, such as the common cold, pneumonia, and gonorrhea, do not induce effective or lasting immunity and may be contracted repeatedly.

b. **Artificial Immunity.** In the case of some infectious which result in naturally acquired immunity, it is possible to stimulate this products) into the person's body. This process is called "vaccination" or "immunization." Usually, in order to obtain a protecting level of immunity, it is necessary to give several doses of the vaccine at successive intervals of a few weeks or few months. This is called the initial series. Thereafter, because the immunity is gradually lost, it is necessary to have "booster" doses at periodic intervals in order to restore and adequate level of resistance. At present, effective artificial immunization is available against a limited number of diseases, including smallpox, typhoid, tetanus, diphtheria, cholera, epidemic typhus, plague, yellow fever, poliomyelitis, and some others. Artificial immunization does not provide absolute protection against the specific disease nor does it protect against other disease. Consequently, protective measures such as personal hygiene and sanitation must never be relaxed because of a feeling of security that one has been "immunized."

## 1-18. COMMUNICABLE DISEASE CONTROL MEASURES

The Army is vitally concerned with keeping the soldier mentally and physically fit. His commander and his medical officer use every available means to make certain that he is given the best health protection available. In this effort, all three factors involved in the spread of communicable diseases are taken into consideration, namely, the source of disease, the transmitting agency, and the susceptible person.

## 1-19. CONTROL OF THE DISEASE SOURCE

One means of breaking the chain of disease transmission is through measures for controlling sick individuals (cases), carriers, and animal reservoirs. These control measures include isolation, quarantine, medical surveillance, treatment, and personal hygiene.

a. **Isolation.** Isolation is a procedure whereby infected persons (cases or carriers) are separated from other individuals. Usually this separation is accomplished by having the patient admitted to the isolation ward in the hospital. Clothing and linens used by infected individuals are laundered with soap and hot water. Other contaminated articles are washed, scrubbed, aired, sunned, or incinerated as appropriate to the article. Mattresses and pillows used by apparently well persons should be sunned at intervals to destroy and bacteria that may be on them.

b. **Quarantine.** Quarantine is the restriction of freedom of movement of those individuals who may have been in contact with a case and who may themselves develop and further spread the disease. In this case, the individual is only suspected of having a contagious disease; however, if an individual is known to have a disease of a communicable nature, he may likely be placed in isolation rather than in quarantine.

c. **Medical Surveillance.** This measure may be carried out in two ways:

(1) When cases or suspected cases of certain communicable diseases occur in a command, all persons who are their contacts may be inspected daily during the incubation (developmental) period of the disease in order to detect new cases of the disease that may be developing.

(2) In the presence of a threatened epidemic, examinations of all troops may be ordered at stated intervals for the purpose of detecting early cases.

d. **Treatment.** When discovered, all cases of disease are treated. In this way, the disease agents are destroyed and will not spread further.

e. **Personal Hygiene.** The spread of disease agents from infected individuals can be prevented or greatly reduced by careful observance of the rules of personal hygiene--by strictly adhering to healthful habits and practices.

f. **Animal Reservoirs.** Control of animal reservoirs which tend to live in close proximity to man will do much to reduce the communicable disease hazard. Rats are reservoirs for a number of diseases, including plague, leptospirosis, murine typhus, enteric salmonellosis, rat bite fever, and trichinosis. They may transmit these diseases to humans through fleas, by contaminating food or water, or by other means. Mice also are health hazards. Rats and mice should be exterminated; the usual method is by poisoning. In addition, denying rodents access to food, water, and shelter will prevent new colonies from being established in the area. Quarantine and immunization of



domestic animals may sometimes be required to help prevent the spread of other diseases, such as rabies and tuberculosis. Household pets, especially dogs, may be sources of disease.

## **1-20. CONTROL OF VEHICLE OR TRANSMITTING AGENT**

To prevent the transmission of disease organisms, the following measures of environmental sanitation should be practiced as rigidly as possible:

- a. Avoidance of overcrowding and close physical contact.
- b. Proper ventilation of living quarters.
- c. Water purification.
- d. Careful selection and preparation of food.
- e. Maintenance of food service sanitation.
- f. Sanitary waste disposal.
- g. Proper control of disease-bearing arthropods and animals.
- h. Encouragement of the individual practice of personal hygiene.

## **1-21. PROTECTION OF THE SUSCEPTIBLE PERSON**

In general, susceptibles should be protected by all measures which improve general health. It is a well-known fact that the individual who has good mental and physical health has good resistance to disease. Other protective measures include:

a. **Personal Hygiene.** The practice of personal hygiene will assist in preventing disease agents from entering the body.

b. **Immunization.** While immunization is an excellent method of control for some diseases, it cannot be relied on completely. It should be used in conjunction with other control measures. Immunizations are rarely 100 percent effective in preventing a disease.

c. **Prophylaxis.** Prophylaxis refers to a direct measure used to prevent or help prevent a disease. As a prophylactic measure, certain drugs may be given to members of a command to combat epidemic diseases, such as streptococcal sore throat. Venereal diseases are sometimes prevented by prompt cleansing of the contaminated parts of the body with soap and water; however, some contaminated parts cannot be reached with soap and water. Other diseases, including malaria, may be prevented or suppressed by medication given before exposure to the disease, but such prophylaxis should be used only upon orders of competent medical authority.

d. **Adequate Nutrition.** An improperly nourished body is especially susceptible to the invasion of disease germs. To remain "healthy," an individual should eat foods rich in vitamins and protein.

e. **Adequate Rest.** Insufficient rest prevents the body from rebuilding cells that have been used to provide energy for mental and physical activities.

**Continue with Exercises**

## EXERCISE, LESSON 1

**INSTRUCTIONS.** The following exercises are to be answered by marking the lettered response that best answers the question or best completes the incomplete statement.

After you have completed all the exercises, turn to, "Solutions to Exercises" at the end of the lesson and check your answers.

1. Which of the following area is not generally included under Preventive Medicine functions?
  - a. Recommend hearing protection.
  - b. Job-specific medical surveillance.
  - c. Physical evaluation boards.
  - d. Occupational carcinogens.
  
2. During wartime, the largest number of hospital admissions in military hospitals is the result of which of the following?
  - a. Combat casualties.
  - b. Disease problems.
  - c. None combat injuries.
  - d. Neuropsychiatric problems.
  - e. Pregnancy.

3. Choose the one best answer. Which of the following is a primary Preventive Medicine responsibility at a garrison installation?
  - a. Gather monthly statistics concerning venereal disease incidence.
  - b. Ensure quality control of the laboratory diagnostic procedures for venereal diseases.
  - c. Supervise the hospital infection control committee.
  - d. Preventive maintenance for a pesticide spraying apparatus.
  
4. Choose the one best answer. Which of the following is a primary preventive medicine responsibility at a fixed installation?
  - a. Develop and evaluate a vaccine for gonorrhea.
  - b. Supervise the medical management of patients hospitalized with malaria.
  - c. Monitor the incidence of rabies in the skunk population.
  - d. Inventory of industrial health hazards.
  
5. Preventive medicine is vital in our efforts to maintain an effective fighting force in combat because:
  - a. Preventive Medicine personnel treat combat wounded.
  - b. Overall, 80 percent of hospital admissions during wartime are for disease and preventable non-combat injuries.
  - c. Preventive Medicine personnel inspect prostitutes to ensure they use birth control pills.
  - d. Preventive Medicine personnel issue clothing to troops in order to prevent cold injuries.
  - e. Preventive Medicine personnel tell commanders when and where it is safe to engage the enemy.

**Check Your Answers on Next Page**

## **SOLUTIONS TO EXERCISE, LESSON 1**

1. c (para 1-4)
2. b (para 1-2b)
3. a (para 1-4a)
4. d (para 1-1)
5. b (para 1-2b)

**End of Lesson 1**

## **LESSON ASSIGNMENT**

### **LESSON 2**

The Army Immunization Program.

### **LESSON ASSIGNMENT**

Paragraphs 2-1 through 2-7.

### **LESSON OBJECTIVES**

After completing this lesson, you should be able to:

- 2-1. Identify the major physiological concepts of immunology.
- 2-2. Identify the routine and special immunizations administered by the Army.
- 2-3. Identify the major provision of the Army Immunization Program with respect to military and dependent populations.

### **SUGGESTION**

After completing the assignment, complete the exercises at the end of this lesson. These exercises will help you to achieve the lesson objectives.

## LESSON 2

### THE ARMY IMMUNIZATION PROGRAM

#### 2-1. IMMUNIZATION

The primary purpose of the Army Immunization Program is to prevent disease that might interfere with accomplishment of the military mission. Toward this end, standards for handling, storage, and quality control of biological products are set up; immunizations for "routine" and "special" circumstances are selected; dosages and dose intervals are prescribed; measures for control of undesirable side effects are required; and appropriate records of immunizations are initiated and maintained.

a. **Standards.** All biologicals obtained in this country for use in the Armed Forces conform to the National Institute of Health (NIH) requirements for the production and sale of such materials. If procured abroad, these products must conform to standards equivalent to those of NIH. Expiration periods are based on previous experience with these or similar agents and studies of the rate at which they lose immunizing potency. Immunizing agents may not be used beyond the stated expiration dates without specific authority from The Surgeon General. As a general policy, biological products should not be ordered in quantities so great that they will not be used before their date of expiration. Oral poliovirus vaccine and yellow fever vaccine must always be shipped and stored at freezing temperatures (below 32°F or 0°C). All other biologicals should be stored at temperatures between 2° and 8°C (35.6° to 46.4°F) and should not be frozen.

b. **Responsibilities.** Maintenance of personnel in a current immune status is a command responsibility. Unit personnel officers are required to check the immunization status of each person in their units at appropriate intervals.

c. **References.** Technical information pertaining to immunizations, including a list of standard Army stock items of biologicals, may be found in TB MED 114. Administrative requirements and procedures for implementation of the program are contained in AR 40-562. Because of the changing nature of immunization requirements and new research data, the information contained in this subcourse is of a general nature and reflects requirements as of this date. For more up-to-date details, the appropriate current publication should be consulted.

#### 2-2. ROUTINE IMMUNIZATIONS

Routine immunizations are those which are routinely administered to all military personnel entering on active duty for periods in excess of 30 days. Routine immunizations are further categorized according to specific geographical areas of the world in which the prevalence of a particular disease warrants immunization. Figure 2-1 illustrates graphically the geographical areas requiring specific immunizations. Routine immunization requirements may be found in AR 40-562.

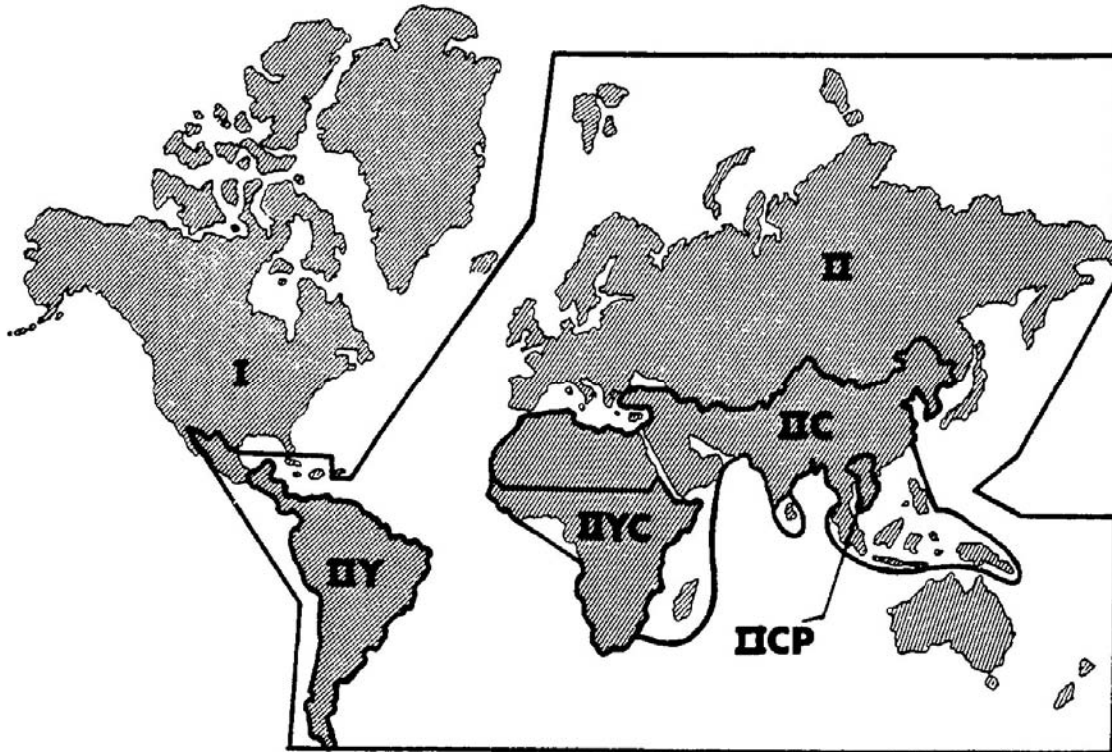

Figure 2-1. Geographical areas requiring specific immunizations.

### 2-3. IMMUNITY AND RESISTANCE

A susceptible or nonimmune has little resistance against a particular disease organism and, if exposed to it, is liable to contract the disease. By contrast, an immune has a high degree of resistance to the organism and, when exposed, does not develop the disease. While most babies are born with a high level of immunity to many disease organisms, this immunity is lost within a few months. The immunity possessed by adults usually is acquired either naturally or artificially after birth and may be temporary or permanent. The basic component of immunity or specific resistance is the antibody. Antibodies are proteins produced by the body system in response to stimulation by a foreign substance (antigen) and having the capacity for combining specifically with that substance. Immunization may be active or passive.

a. **Active.** In active immunization, antibodies are formed within the body because of the presence of the natural infection (natural immunity) or because of the inoculation into the body of infectious agents or antigenic substances derived there from (artificial immunity). In active immunity, a physical change is effected which is relatively slow in developing (10 to 114 days), but whereby a permanent immune pattern is created. While the level of active immunity may decline over a period of years, it is susceptible to stimulation and elevation by a relatively small amount of immunizing material. The immunizing material comprising the vaccine that is inoculated may be either weakened (attenuated) or killed (inactivated) disease organisms or their products.



b. **Passive.** In passive immunization, antibodies that have been preformed in humans or animals are injected into the body of a susceptible. The duration of this type of immunity depends upon the persistence of the injected antibodies and is usually not longer than a few weeks. While immunity is immediate, no permanent immune pattern is set up. Therefore, passive immunizations are used primarily in specific emergencies to prevent hepatitis, rabies, pertussis in babies, measles in contacts, and tetanus in unimmunized wounded individuals.

## 2-4. TYPES OF VACCINES

a. **Active Immunity.** The Army uses three kinds of vaccines to induce active immunity: attenuated live organisms, inactivated organisms, and products of organisms. The type of vaccine must always be kept in mind when determining how a vaccine will be used, since the responses differ.

(1) Live organisms. Vaccines that consist of suspensions of attenuated (weakened) live organisms--bacteria or viruses--include smallpox, poliomyelitis, yellow fever, measles, mumps, rubella, and adenovirus. A single injection of such a vaccine, properly prepared, stored, and used so that it retains required viability (potency), usually provides a fairly rapid, ample, and lasting immune response.

(2) Inactivated (killed) organisms. Vaccines made from inactivated organisms include influenza, typhoid fever, cholera, plague, and rabies. A single injection of most inactivated vaccines may produce only a scarcely detectable response. The first injection, however, orients the body so that subsequent injections produce successively larger responses. It is for these reasons that immunization against typhoid fever, cholera, typhus, tetanus, and other diseases for which nonliving vaccines are utilized is carried out by a series of injections.

(3) Products of organisms. Toxoids consist of chemically inactivated bacterial poisons injected into individuals to induce the formation of antibodies against the original bacterial toxin. The two commonly used toxoids are tetanus and diphtheria toxoids.

b. **Passive Immunity.** Passive immunity depends upon the presence of injected, preformed antibodies. The source of such antibodies is serum globulin, a concentrated fraction of blood plasma from human beings or animals. Immune serum globulin (gamma globulin) contains the dominant form of antibodies found in the blood of normal adult human beings. In practice, it has been found to be of value as a prophylaxis against type A hepatitis, measles, and, in a marginal sense, of poliomyelitis and rubella. Immune globulin preparations for measles, vaccinia, pertussis, mumps, rabies, and tetanus are obtained by hyper-immunization of human beings or from persons with high antibody titers.

## 2-5. PERSONS SUBJECT TO ROUTINE IMMUNIZATIONS

### a. Military Personnel.

(1) Active duty. All personnel entering on active duty for periods in excess of 30 days will receive the routine immunizations listed in Table 2-1.

| Immunization Routine  | Basic Series  | Boosters  | Method                        | Contra indications                       | Adverse Reactions   |
|---|---|---|-------------------------------|--|---|
| Smallpox  |   | 5 years   | Multiple pressure intradermal | eczema<br>pregnancy<br>immunosuppression | encephalitis<br>eczema vacci-<br>natum<br>gen. vaccinia<br>auto-inoculation |
| Tetanus<br>Diphtheria<br>Toxoid                             | 3 injections<br>1. 0.5 ml<br>2. 0.5 ml 1-<br>2 mos. later<br>3. 0.1 ml 12<br>mons after<br>2nd dose | 0.1 ml 10<br>years 0.5 ml<br>after wound<br>or burn if no<br>booster<br>within 5<br>years | SC/IM                         | hypersensitivity                         | local induration<br>urticaria   |
| Poliomyelitis   | 3 doses<br>(trivalent)<br>#2. 6-8<br>weeks later<br>#3. 12 mos<br>after #2                          | none  | oral                          | leukemia<br>lymphoma<br>steroid therapy  | questionable<br>paralytic disease<br><1/3,000,000                           |
| Influenza   | 0.5 ml  | annual  | SC/IM                         | egg<br>hypersensitivity                  | local/systemic<br>toxic   |
| <u>Yellow Fever</u><br>Alert Forces<br>certain travel       | 0.5 ml  | 10 years  | SC/IM                         | egg<br>hypersensitivity                  | febrile reaction<br>rare<br>encephalopathy                                  |
| <u>Cholera</u><br>Only for entry<br>to certain<br>countries | 0.5 ml  | 6 months<br>only on<br>advice of<br>command<br>surgeon                                    | SC/IM                         |  | local/systemic<br>toxic   |
|   |   |   |                               |  |   |

Table 2-1. Schedule of immunizations, adult (cont'd).

| <b>Immunization<br/>Special/<br/>indications</b>                                  | <b>Basic<br/>Series</b>   | <b>Boosters</b>                         | <b>Method</b> | <b>Contra<br/>indications</b> | <b>Adverse<br/>Reactions</b>     |
|---|---|---|---------------|-------------------------------|----------------------------------|
| <u>Typhoid</u><br>Occ travel<br>Alert Forces                                      | For travel 2 inj.<br>0.5 ml 4 or<br>more weeks<br>apart Alert<br>Forces 0.5 ml<br>repeat upon<br>deployment                         | 3 years<br>0.5 ml                       | SC/IM         |                               | local/systemic toxic             |
| <u>Plague</u><br>Alert Forces<br>rare civil travel                                | 2 injections<br>1. 1.0 ml<br>2. 0.2 ml 3<br>mos later   | 6 months<br>0.2 ml                      | IM            |                               | local/systemic toxic             |
| <u>Rabies (HDCV)</u><br>High risk occup<br>occ special<br>forces<br>Post-exposure | Pre-exposure:<br>3 inj 0.1 ml at 7<br>days and 21 to<br>28 days<br>Post exposure:<br>5 inj 1.0 ml at<br>days 0, 3, 7,<br>14, and 28 | 2 years<br>0.1 ml<br>(pre-<br>exposure) | IM            |                               | occasional local                 |
| <u>Immune<br/>Globulin</u><br>For Hepatitis A<br>occ travel<br>Post-exposure      | Pre-exposure:<br><3 mos -- 2 ml<br>>5 mos -- 5 ml<br>Post-exposure:<br>0.01 ml/ lb  | 4-6 mos (pre-<br>exposure)              | IM            |                               | rare, local toxic                |
| <u>Hepatitis B</u><br>High risk<br>groups   | 3 inj: 1.0 ml at<br>day 0, 1 month,<br>and 6 months   | Unknown                                 | IM            |                               | minimal, local                   |
| <u>Adenovirus</u><br>Recruits   | 1 capsule<br>type 4, 7, 21  | none                                    | oral          |                               | pharyngitis if capsule<br>bitten |
| <u>Meningococcus</u><br>Recruits  | Single injection<br>0.5 ml<br>Types A, C, Y,<br>W-135   | none                                    | SC            |                               | local, toxic                     |
| <u>Measles<br/>(Rubella)</u><br>Recruits  | Single injection<br>Usually as<br>Measles-<br>Rubella   | none                                    | SC            |                               | local, rare rash                 |
| <u>Rubella</u><br>Recruits  | Single injection<br>Usually as<br>Measles-<br>Rubella   | none                                    | SC            | Pregnancy                     | Minor rash                       |

Table 2-1. Schedule of immunizations, adult (concluded).

(2) Alert forces. Members of units and individuals who have been designated to be in a state of readiness for immediate deployment outside of Area 1 will receive the immunizations required for Area II within 30 days of notification or sooner.

(3) Reserve Component personnel.

(a) Members of the Reserve Components, including ROTC students, who are ordered to active duty or active duty for training for 30 days or less will receive, prior to departing their homes or educational institutions for duty, smallpox, tetanus-diphtheria, and poliovirus immunizations.

(b) Individuals in (a), above, whose duties will require travel outside area will receive the immunizations prescribed for active duty personnel.

(c) Members of Reserve Components who have been designated, either individually or as members of a unit, to be in a state of readiness within 30 days or less of notification will receive, in addition to (a), above, influenza, yellow fever, typhoid, and the basic series for plague and cholera.

(d) Members of Reserve Components, other than ROTC students, ordered to active duty or active duty for training for more than 30 days, will receive the immunizations prescribed for active duty personnel.

**b. Military Dependents**

(1) For dependents who remain in Area I, the following immunizations are recommended on a voluntary basis:

(a) Tetanus-diphtheria.

(b) Oral poliovirus.

(2) Dependents traveling outside of Area 1 under Armed Forces' sponsorship will receive typhoid, tetanus-diphtheria, and oral poliovirus immunizations and/or reimmunizations. Influenza immunization is recommended on a voluntary basis.

**c. Federal Civilian Employees and Their Dependents.** Federal civilian employees and their dependents who travel outside Area 1 under Armed Forces' sponsorship will receive the immunizations prescribed in b(2), above, without charge to the individual.

d. **Exemptions and Waivers.** Exemptions are granted for medical reasons; waivers are granted for administrative reasons.

(1) Exemptions. A staff surgeon or commanding officer of a medical treatment facility may issue an exemption from immunizations for a valid medical reason. A medical exemption may constitute an assignment limitation, and an individual with such a limitation will not be assigned to a country where the disease is endemic.

(2) Waivers. The Surgeon General may grant waivers of immunization requirements. Such waivers are usually granted on the basis of legitimate religious objection to immunization. Such waivers will constitute assignment limitations as in (1), above. Waivers are subject to revocation when the accomplishment of a military mission may be compromised. Persons granted waivers must be counseled as to the following:

(a) The additional risk to health on exposure to disease against which the individual will not be protected.

(b) The possibility that the individual may be detained at international borders in accordance with international health regulations.

(c) The possibility that the waiver may be revoked in the interest of military necessity, and that he may be immunized involuntarily--by force, if necessary.

e. **Delineation of Specific Geographic Areas and Their General Immunization Requirements.** Immunization requirements for travel to or through, or duty in specific geographic areas, are given in succeeding paragraphs. In Area II (designated on the map (figure 2-1) by numbers), the letter symbolizes the immunizations required for that area in addition to those designated for Area I.

(1) Area I. Area I includes the United States, Canada, Greenland, Iceland, Kwajalein Atoll (Marshall Islands), Guam, and all Pacific Ocean Islands east of the 180th Meridian, the North and South Polar Regions including the Antarctic continent, Bermuda, the Bahama Islands, Baja, California, the area in Mexico north of a line 50 miles south of the US-Mexico border and the Naval Base, Guantanamo Bay, Cuba.

(2) Area II. Area II includes Areas IIP, ILY, and all other areas outside Area I. Immunizations and reimmunizations required for all persons subject to this regulation traveling to or through, or residing in Area II, are those listed in Table 2-1.

(3) Area IIP. Area IIP includes Cambodia, Laos, and Vietnam. Immunizations required of all persons subject to this regulation traveling through or residing in Area IIP are those for Area II, plus plague.

(4) Area ILY. Area ILY includes Central America southeast of the Isthmus of Tehuantepec, Panama, South America, and Africa south of the Sahara. Immunizations required of all persons subject to this regulation traveling through or residing in Area ILY are those for Area II plus yellow fever. Yellow fever immunization is also required for travel from Area ILY to yellow fever receptive areas, as indicated on figure 2-1, with the exception of the US.

## 2-6. SPECIAL IMMUNIZATIONS

Special immunizations are those that are administered selectively to certain categories of persons or in the event of unusual circumstances. The following immunizations are administered by the Army on a selective basis.

a. **Adenovirus Vaccine and Meningococcal Vaccine.** The Surgeon General of the Army has the sole authority to direct the use of these two vaccines. They are administered only to basic trainees (includes recruits, inductees, and all others without prior service), who, as a group, make up the vast majority of cases of these two diseases.

b. **Measles Vaccine.** Measles vaccine is recommended for children age 1 through 14 years who have not had natural measles.

c. **Rubella Vaccine.** Rubella (German measles) vaccine is recommended for children age 1 through 14 who have not had natural rubella (German measles).

d. **Diphtheria and Tetanus Toxoids and Pertussis Vaccine, Absorbed.** Diphtheria and Tetanus Toxoids and Pertussis Vaccine, Absorbed (DPT) is recommended for children from 2-3 months through 6 years of age.

e. **Mumps Vaccine.** This vaccine is recommended for use only during outbreaks of mumps, to be administered to all persons age 12 months or older who have not had natural mumps. It is of particular value in children approaching puberty, in adolescents, and in adults, especially males.

f. **Tetanus Immune Globulin (Human) and Tetanus Antitoxin.** When the status of previous immunization is such that there is no assurance of circulating antibody at the time an injury occurs, passive protection must be provided by the use of tetanus immune globulin (human). Tetanus antitoxin (from horse serum) is used only when tetanus immune globulin is not available.

**g. Human Diploid Cell Rabies Vaccine, Human Rabies Immune Globulin.** Human Diploid Cell Rabies Vaccine (HDCV), Human Rabies Immune Globulin (HRIG) products, like those in f, above, differ from most immunizing agents, where others are not, these are usually used after an exposure to the disease has occurred. Protection against rabies depends upon active immunization, with the production of antibodies, in response to an inactivated vaccine. Human Diploid Cell Rabies Vaccine, elicits such a response; however, several days elapse after injections are started before antibodies can be detected in the serum. During this period, the virus inoculated by the bite of an animal may gain entry into nerves. To provide an immediate barrier to the virus, passive protection may be provided with HRIG. This temporarily slows down or halts the spread of the virus, allowing time for active immunity to develop. Therefore, the complete antirabies prophylaxis consists of a single dose of HRIG/antirabies serum (for temporary, passive protection) followed by five doses of HDCV (to induce active immunity).

## **2-7. RECORDS OF IMMUNIZATION**

**a. Military Personnel.** At the time of initial immunization of a person entering the Army, two records are prepared: International Certificates of Vaccination (PHS Form 731) and Health Record Immunization Record (Standard Form 601). All immunizations administered to an individual are recorded on both of these forms.

(1) The PHS Form 731 (figure 2-2) is the individual's personal "shot record" and is to be carried when performing international travel and at such other times as local commanders may direct.

(2) The SF 601 (figure 2-3 and figure 2-4) is the record copy of the individual's immunization status and is retained in his health record.

**b. Nonmilitary Personnel.** At the time of initial immunization of nonmilitary personnel, PHS form 731 is prepared. Entries may also be based upon transcripts of official records and transcripts from written statements of civilian physicians. The PHS Form 731 is retained by the individual to be carried when performing international travel or as needed.

**INTERNATIONAL CERTIFICATES OF  
VACCINATION**

AS APPROVED BY  
**THE WORLD HEALTH ORGANIZATION**  
(EXCEPT FOR ADDRESS OF VACCINATOR)

**CERTIFICATS INTERNATIONAUX DE  
VACCINATION**

APPROUVÉS PAR  
**L'ORGANISATION MONDIALE DE LA SANTÉ**  
(SAUF L'ADRESSE DU VACCINATEUR)

THOMPSON, RAY A. 625-97-0853  
TRAVELER'S NAME-NOM DU VOYAGEUR

The Adjutant General, ATTN: AGPF  
ADDRESS-ADRESSE (Number-Numéro) (Street-Rue)

Dept. of the Army  
(City-Ville)

Washington, D.C. 20315  
(County-Département) (State-État)

**SAMPLE**



**U.S. DEPARTMENT OF  
HEALTH, EDUCATION, AND WELFARE  
PUBLIC HEALTH SERVICE**

PHS-731 (REV. 9-77)

Figure 2-2. PHS Form 731 (International Certificates of Vaccination).



| HEALTH RECORD   |         | IMMUNIZATION RECORD |                  |  |                  | <i>All entries in ink to be made in block letters</i> |                  |                  |
|---|---------|---------------------|------------------|--|------------------|---|------------------|------------------|
| <b>VACCINATION AGAINST SMALLPOX</b> <i>(Number of previous vaccination scars)</i> |         |                     |                  |  |                  |   |                  |                  |
|   | DATE    | ORIGIN              | BATCH NUMBER     | REACTION   | STATION          | PHYSICIAN'S NAME                                      |                  |                  |
| 1   |         |                     |                  |  |                  |   |                  |                  |
| 2   |         |                     |                  |  |                  |   |                  |                  |
| 3   |         |                     |                  |  |                  |   |                  |                  |
| 4   |         |                     |                  |  |                  |   |                  |                  |
| 5   |         |                     |                  |  |                  |   |                  |                  |
| 6   |         |                     |                  |  |                  |   |                  |                  |
| <b>YELLOW FEVER VACCINE</b>   |         |                     |                  |  |                  |   |                  |                  |
|   | DATE    | ORIGIN              | BATCH NUMBER     | STATION  |                  | PHYSICIAN'S NAME                                      |                  |                  |
| 1   | 05Jan98 | Nat'l Drug Company  | Y101             | Naval Base, Norfolk, VA  |                  | J. B. Doe   |                  |                  |
| 2   |         |                     |                  |  |                  |   |                  |                  |
| 3   |         |                     |                  |  |                  |   |                  |                  |
| <b>TYPHOID VACCINE</b>  |         |                     |                  |  |                  |   |                  |                  |
|   | DATE    | DOSE                | PHYSICIAN'S NAME |  | DATE             | DOSE  | PHYSICIAN'S NAME |                  |
| 1   | 07Jun95 | Vi 0.5/<br>Q 2 yrs  | A. B. Smith      | 4  |                  |   |                  |                  |
| 2   | 23Jul97 | 4 caps/<br>Q 5 yrs  | W. T. Door       | 5  |                  |   |                  |                  |
| 3   |         |                     |                  | 6  |                  |   |                  |                  |
| <b>TETANUS-DIPHTHERIA TOXOIDS</b>   |         |                     |                  |  |                  |   |                  |                  |
|   | DATE    | DOSE                | PHYSICIAN'S NAME |  | DATE             | DOSE  | PHYSICIAN'S NAME |                  |
| 1   | 05Jan98 | 0.5 cc              | J. B. Doe        | 4  |                  |   |                  |                  |
| 2   |         |                     |                  | 5  |                  |   |                  |                  |
| 3   |         |                     |                  | 6  |                  |   |                  |                  |
| <b>CHOLERA VACCINE</b>  |         |                     |                  |  |                  |   |                  |                  |
|   | DATE    | PHYSICIAN'S NAME    |                  | DATE   | PHYSICIAN'S NAME |   | DATE             | PHYSICIAN'S NAME |
| 1   | 12Jan98 | J. B. Doe           | 4                |  |                  | 7   |                  |                  |
| 2   |         |                     | 5                |  |                  | 8   |                  |                  |
| 3   |         |                     | 6                |  |                  | 9   |                  |                  |
| <b>PATIENT'S IDENTIFICATION</b> <i>(Mechanically Imprint, Type of Print):</i>     |         |                     |                  |  |                  |   |                  |                  |
| SEAMAN, Able B.<br>Male 09May75<br>YN2 N/AD<br>20-123-45-6789                     |         |                     |                  | Patient's Name— last, first, middle initial;<br>Sex; Age or Year of Birth; Relationship to Sponsor;<br>Component/Status; Department/Service.                                     |                  |   |                  |                  |
|   |         |                     |                  | Sponsor's Name— last, first, middle initial;<br>Rank/Grade; SSN or Identification Number;<br>Organization.   |                  |   |                  |                  |
| 60-106  |         |                     |                  | <b>IMMUNIZATION RECORD</b><br>Standard Form 601, October 1975 (Rev)<br>General Services Administration & Interagency<br>Committee on Medical Records<br>FORM (41 CFR) 201-45.516 |                  |   |                  |                  |

HM31206A

Figure 2-3. Standard Form 601 (Health Record-Immunization Record) (Front).

| ORAL POLIOVIRUS VACCINE   |         |              |                  |                  |         |                  |                  |                  |             |
|---|---------|--------------|------------------|------------------|---------|------------------|------------------|------------------|-------------|
|   | DATE    | DOSE         | PHYSICIAN'S NAME |                  | DATE    | DOSE             | PHYSICIAN'S NAME |                  |             |
| 1   | 05Jun00 | 0.5cc        | J. R. Frost      | 3                |         |                  |                  |                  |             |
| 2   |         |              |                  | 4                |         |                  |                  |                  |             |
| INFLUENZA VACCINE   |         |              |                  |                  |         |                  |                  |                  |             |
|   | DATE    | DOSE         | PHYSICIAN'S NAME |                  | DATE    | DOSE             | PHYSICIAN'S NAME |                  |             |
| 3   | 15Nov96 | 0.5cc        | A. B. Smith      | 3                | 01Nov98 | 0.5cc            | J. B. Doe        |                  |             |
| 4   | 15Oct97 | 0.5cc        | W. T. Door       | 4                | 20Oct99 | 0.5cc            | J. R. Frost      |                  |             |
| OTHER IMMUNIZATIONS   |         |              |                  |                  |         |                  |                  |                  |             |
|   | DATE    | TYPE         | DOSE             | PHYSICIAN'S NAME | DATE    | TYPE             | DOSE             | PHYSICIAN'S NAME |             |
| 1   | 27Aug99 | MMR          |                  | J. R. Frost      | 5       | 06Jun00          | HepatitisA#2     | 1.0cc            | J. R. Frost |
| 2   | 16Nov99 | Varicella #1 | 0.5cc            | J. R. Frost      | 6       |                  |                  |                  |             |
| 3   | 16Dec99 | Varicella #2 | 0.5cc            | J. R. Frost      | 7       |                  |                  |                  |             |
| 4   | 23Dec99 | HepatitisA#1 | 0.1cc            | J. R. Frost      | 8       |                  |                  |                  |             |
| SENSITIVITY TEST ( <i>Tuberculin, etc.</i> )  |         |              |                  |                  |         |                  |                  |                  |             |
|   | DATE    | TYPE         | DOSE             | ROUTE            | RESULT  | PHYSICIAN'S NAME |                  |                  |             |
| 1   | 16Nov98 | TB (Mantoux) | 0.1cc            | Intradermal      | zero mm | J. B. Doe        |                  |                  |             |
| 2   |         |              |                  |                  |         |                  |                  |                  |             |
| 3   |         |              |                  |                  |         |                  |                  |                  |             |
| 4   |         |              |                  |                  |         |                  |                  |                  |             |
| 5   |         |              |                  |                  |         |                  |                  |                  |             |
| <b>REMARKS:</b>   |         |              |                  |                  |         |                  |                  |                  |             |
| (1) HYPERSENSITIVITY TO ASPIRIN   |         |              |                  |                  |         |                  |                  |                  |             |
| (2) HISTORY MODERATELY SEVERE REACTION TO PARENTERAL PENICILLIN IN 1995             |         |              |                  |                  |         |                  |                  |                  |             |
| THIS RECORD IS ISSUED IN ACCORDANCE WITH ARTICLE 99, WHO SANITARY REGULATION NO. 2. |         |              |                  |                  |         |                  |                  |                  |             |

HM361206B

Figure 2-4. Standard Form 601 (Health Record-Immunization Record) (Back).

**Continue with Exercises**

## EXERCISES, LESSON 2

**INSTRUCTIONS.** The following exercises are to be answered by marking the lettered response that best answers the question or best completes the incomplete statement or by writing the answer in the space provided.

After you have completed all the exercises, turn to "Solutions to Exercises" at the end of the lesson and check your answers.

1. The substance which affords immunity against a disease is known as an  
\_\_\_\_\_
  
2. Immunity acquired by catching a disease such as mumps or chickenpox (varicella) is said to be:
  - a. Natural.
  - b. Artificial.
  - c. Active.
  - d. Passive.
  
3. Immunity acquired by inoculation with antibodies which were performed in the body of a laboratory animal is said to be:
  - a. Natural.
  - b. Artificial.
  - c. Active.
  - d. Passive.
  
4. Active immunity has a \_\_\_\_\_ residual effect than passive immunity.
  - a. Shorter.
  - b. Longer.

5. A routine immunization is one that is:
  - a. Administered to all military personnel.
  - b. Administered only in special situations.
  - c. Administered to all military personnel and their dependents under routine conditions.
  - d. Administered to all military personnel stationed in or alerted for the geographical area in which the immunization is prescribed.
  
6. Military dependents are required to receive immunizations only:
  - a. In the event of an epidemic.
  - b. If they are under the age of 18.
  - c. When crossing international borders.
  - d. When traveling overseas under Armed Forces' sponsorship.
  
7. Which of the following vaccines contain attenuated live organisms? (may be more than one correct answer)
  - a. Antirabies serum.
  - b. Smallpox.
  - c. Tetanus toxoid.
  - d. Poliovirus.
  - e. Diphtheria toxoid.
  - f. Gamma globulin.

8. Under what conditions is a soldier required to carry his PHS Form 731 (International Certificates of Vaccination)?
  - a. Whenever in uniform.
  - b. When crossing state lines.
  - c. When performing international travel.
  - d. When flying in military aircraft.
  
9. SF 601 (Immunization Record) always remains:
  - a. In the soldier's possession.
  - b. In the medical facility where the immunizations were administered.
  - c. In the soldier's health record.
  - d. In the soldier's 201 file.
  
10. Adenovirus and meningitis vaccines are administered only to \_\_\_\_\_ at the direction of \_\_\_\_\_.
  
11. An administrative waiver to immunization requirements:
  - a. Can be terminated for military necessity.
  - b. Can be terminated only by the chaplain.
  - c. Is granted when an individual is allergic to an immunizing agent.

**Check Your Answers on Next Page**

## **SOLUTIONS TO EXERCISES, LESSON 2**

1. antibody (para 2-3)
2. c (para 2-3a)
3. d (para 2-3b)
4. b (para 2-3)
5. d (para 2-1)
6. d (para 2-5b)
7. b  
d (para 2-4a(1))
8. c (para 2-7)
9. c (para 2-7)
10. basic trainees, The Surgeon General of the Army. (para 2-6)
11. a (para 2-5d(2))

**End of Lesson 2**

## **LESSON ASSIGNMENT**

### **LESSON 3**

Field Forces/Fixed Installation.

### **LESSON ASSIGNMENT**

Paragraphs 3-1 through 3-10.

### **LESSON OBJECTIVES**

After completing this lesson, you should be able to:

- 3-1. Identify the major disease problems encountered by military units both in the field and fixed installations.
- 3-2. Identify the AMEDD preventive medicine resources in support of troops in combat and in fixed installations.

### **SUGGESTION**

After completing the assignment, complete the exercises at the end of this lesson. These exercises will help you to achieve the lesson objectives.

## LESSON 3

### FIELD FORCES/FIXED INSTALLATION

#### Section I. MEDICAL THREAT TO FIELD FORCES

##### 3-1. GENERAL

Army preventive medicine may be thought of as functioning in two major areas or situations--in combat (field) operations or in fixed installations. Although some preventive medicine functions overlap in these two areas, there are differences in emphasis because of the variations in organizational structure and logistic support in field operations as opposed to fixed installation (garrison) activities. This section will focus upon the preventive medicine problems and activities which are of primary concern to units operating under field conditions.

##### 3-2. UNIT-LEVEL PREVENTIVE MEDICINE

a. **Responsibilities.** The commander of any military unit is responsible for the health of his command. It is obvious, however, that the maintenance of health in a command is not a one-man job. It requires the wholehearted support of every officer, noncommissioned officer, and enlisted man in the unit. An Army unit--company, battery, or troop--does not normally have any assigned medical personnel; therefore, the tasks of unit-level preventive medicine fall directly upon the shoulders of unit personnel. When a military unit operates under field conditions, it must also assume responsibility for some of the tasks performed by engineer repair and utility personnel in garrison, such as water purification, waste disposal, and spraying against insects and other arthropods.

##### b. **Field Sanitation Team.**

(1) The primary source of assistance to the unit commander in implementing a program of preventive medicine is the field sanitation team. AR 40-5 requires that each company, battery, or similar unit commander appoint a field sanitation team, consisting of at least two men, one of whom must be a noncommissioned officer. Members must have a minimum of six months of remaining duty with the unit at the time of appointment. Since the duty is a non-TOE function in addition to regular duties and since the field sanitation team functions primarily under field conditions, the selection of team members should be made from personnel whose normal field duties will allow them to devote sufficient time to field sanitation activities. Personnel MOS that requires full-time operation under field conditions (such as cooks, clerks, and mechanics) should not be appointed members of the field sanitation team. Team members undergo a 16-hour course of training, conducted by members of preventive medicine units (para 1-20), in the importance of basic sanitation in reducing the incidence of preventable disease, to include the following:



(a) Individual protective measures against arthropods, such as the use of insect repellents, uniform impregnants, and protective clothing.

(b) The use and repair of insect screening and bednets.

(c) The use of residual and space insecticide sprays for the control of flies and related pests.

(d) Rodent control measures.

(e) Food service sanitation.

(f) Unit waste disposal.

(g) Individual water purification procedures.

(h) Residual chlorine determinations in water supplies.

(i) Personal hygiene.

(2) The field sanitation team is not normally functional in garrison, but is in a state of training. In the field, the team conducts control operations within the unit area in the above measures and in all other measures necessary for the protection of health of unit personnel.

c. **Individual Responsibilities.** Although the field sanitation team may provide valuable assistance to the commander, the real success of a unit preventive medicine effort depends upon each individual in the unit. The commander must use the existing chain of command to emphasize to each member of the organization the importance of personal hygiene, sanitation, and individual protective measures against arthropods and other disease vectors. Handwashing devices, field showers, insect repellent, mosquito nets, and other health aids are of little value if the troops do not use them. Therefore, unit-level preventive medicine is largely a matter of education.

### **3-3. UNIT-LEVEL PREVENTIVE MEDICINE ACTIVITIES**

Unit-level preventive medicine focuses primarily on the following major activities:

#### **a. Field Water Supply and Waste Disposal.**

(1) The Corps of Engineers is responsible for supplying potable water, safe to drink, to tactical units in the field. Engineer field water purification equipment is very reliable and produces water of high quality. However, no unit can afford to be complacent. There are many possible sources of contamination in the field after the water has been purified. It is the unit's responsibility to sample the water supply to ensure its potability. In addition, there are times under combat conditions when engineer water supplies are not available to combat troops because of disrupted supply lines, inadequate transportation, and other logistical difficulties.

(2) Trash and garbage constitute a constant problem to military troops in the field. In order to maintain sanitary and liveable campsites, free of rats and other disease vectors, a unit must exercise extreme care over the proper disposal of refuse.

(3) One of the most important aspects of unit-level preventive medicine is the proper construction and maintenance of facilities for the sanitary disposal of human waste.

b. **Food Service Sanitation.** Food service operations in the field, like water supply, are very critical from the standpoint of prevention of intestinal diseases as well as from a morale standpoint. The old expression, "An army travels on its stomach," is more fact than fiction. Any letdown in standards of food service sanitation can result in widespread intestinal disorders and can practically immobilize a unit.

c. **Personal Protective Measures.** Whereas the commander is responsible for the health and welfare of his troops, he must have the support and cooperation of everyone in the unit to achieve and maintain a state of good health in his command. The field sanitation team can aid by constructing handwashing facilities, field showers, and other sanitary devices, but these aids are of value only if the men use them. Many diseases encountered in the field are the direct result of an individual's failure to take proper personal protective measures. These personal protective measures include:

(1) Using insect repellent, rolling down sleeves at night, and using the mosquito net while sleeping.

(2) Use of field sanitary devices for human waste disposal.

(3) Taking the anti-malarial pill regularly. Although this appears to be a simple precaution, experience has shown that administering the pill by roster and observing the soldier swallow it is the only reliable system of prophylaxis.

(4) Bathing as frequently as possible, changing socks and underwear as frequently as practicable, and giving immediate attention to apparently insignificant wounds and infections.

(5) Proper cleaning of the messkit.

(6) Use of individual water purification tablets.

d. **Immunizations.** The unit commander is responsible for ensuring that each individual in his unit receives the required immunizations. He is assisted by the unit personnel officer, who is the custodian of the health records and who is required by Army regulations to screen the records periodically and notify the commander of those individuals requiring immunizations. However, this requirement does not relieve the commander of the responsibility for conducting periodic checks of individual immunization records (PHS Form 731, International Certificate of Vaccination) and

ensuring that immunizations are current. Army regulations also empower the unit commander to require the involuntary immunization of any individual in the presence of an endemic or epidemic disease that is a threat to the effectiveness of the unit. The immunizations are administered by the support medical facility or unit.

### **3-4. DISEASE PREVENTION IN FIELD OPERATIONS**

The primary objective of preventive medicine activities in field operations is the prevention of disease. Although we are concerned with all diseases, there are three major types of diseases of principal concern in the field environment--skin diseases, arthropod-borne diseases, and food and water-borne diseases. The following paragraphs will briefly highlight the critical areas in preventing these diseases.

### **3-5. SKIN DISEASES**

In the field, conditions are much more favorable for the development of skin diseases than in garrison. This is particularly true in tropical and subtropical climates where heat and moisture are prevalent, but it applies to all climatic conditions in one way or another. The basic principle in maintaining healthy skin is to keep the skin clean and dry--a task which may be difficult in the field. Regardless of the difficulty, commanders must constantly emphasize to their men the importance of taking every possible precaution against acquiring skin diseases which spread rapidly under field conditions. Skin diseases fall primarily into the following categories:

a. **Fungus Infections.** Fungus infections are caused by the invasion of the skin by fungi. The company aidman is trained to identify and treat minor fungus infections. For severe or complicated cases, the patient must be seen by a medical officer or physician's assistant. The most important aspect, however, is prevention. Fungi require warmth and humidity; therefore, their prevention and control are based primarily on cleanliness, frequent changes of clothing, and the use of antifungal foot powder--an issue item.

b. **Bacterial Infections.** Bacterial infections, like fungus infections, thrive under conditions of heat and high humidity. The natural flora of the skin contains many bacteria, most of which are harmless. The two that cause the majority of skin infections are Staphylococcus aureus and Beta hemolytic streptococcus. Bacterial infections occur when pathogenic bacteria enter the skin through a cut, scratch, bite, burn, abrasion, or other wound or when they work their way into a hair follicle. Early bacterial infections frequently itch. The soldier scratches and bacteria under the fingernails further spread the infection. The prevention of bacterial infections depends upon eliminating or lessening the conditions favorable to bacterial growth. Washing with soap and water removes many bacteria. Frequent changes to clean, dry clothing and socks inhibit rapid bacterial growth. The friction effect from walking or working in damp clothing can cause chafing, which subjects the soldier to further infection by bacteria or fungi.

c. **Water Immersion Diseases (Injuries).** More appropriately termed injuries than termed diseases, these morbid conditions are a constant hazard to the soldier who must spend long periods of time either wholly or partially submerged in water. The swelling, wrinkling, and whiteness of the skin of the hands when they have been in water for a half hour or so is familiar to everyone. If the skin stays wet for 48 to 72 hours, most people will have visible damage. Depending on the duration of exposure, prolonged immersion in water may cause swelling, discoloration, and desquamation of the skin, resulting in painful and disabling injury. "Trench foot" and "immersion foot" are injuries sustained from prolonged standing in wet socks and boots or immersed in water at temperatures between 32°F and 50°F. They are considered nonfreezing cold injuries as well as immersion diseases. "Paddy foot" is confined to the soles of the feet whereas "warm water immersion foot" includes injury to the entire foot, ankle, and sometimes the lower leg. Prevention of immersion diseases (injuries) is dependent upon frequent changes of clothing and socks and periodic drying and airing of the skin.

### 3-6. ARTHROPOD-BORNE DISEASES AND PARASITES

Arthropod-borne diseases historically have decimated military units in the field. Most of these diseases are caused by organisms that are transmitted by an arthropod vector from the body of an infected person or animal (reservoir) to the body of a susceptible. The prevention of arthropod-borne diseases depends upon proper education of the troops in their causes and the rigid enforcement of individual and unit protective measures. The following are some of the major arthropod-borne diseases of military importance and the principal measures in their prevention.

a. **Malaria.** Caused by the transmission of the infectious agent through the bite of the female Anopheles mosquito, malaria may also be spread from one person to another by blood transfusion or contaminated hypodermic needles. The latter modes are insignificant, however, in considering preventive measures in the field. Malaria prevention consists of two categories of protective measures--physical protection and chemoprophylaxis. Physical measures, or malaria discipline, consist of using insect repellent, mosquito nets, aerosol sprays, and allowing a minimum of exposed skin--especially at night when mosquitoes are most active. Chemoprophylaxis, consisting of weekly administration of the chloroquine-primaquine pill, actually suppresses the symptoms of malaria rather than preventing its presence in the bloodstream. To ensure that every soldier takes his pill, administration should be by roster under the supervision of an NCO.

b. **Plague.** Plague, the disease known as the "black death," which ravaged Europe and Asia in the 14th Century, still exists in some parts of the world. The most common form, bubonic plague, is transmitted to man by the bite of the rat flea. Control measures include immunization of troops in endemic areas, use of individual insecticide powder and aerosol spray in clothing and bedding, and implementing effective rat control measures, particularly by avoiding the accumulation of garbage, trash, and available food sources in bivouac areas.

c. **Typhus Fever.** There are two types of typhus fever--endemic, transmitted to man by the rat flea, and epidemic, transmitted by the body louse. Endemic typhus is prevented in the same manner as plague--by eradicating the reservoir (the rat) and protecting against the vehicle (the flea) by the use of insecticides. Epidemic typhus is prevented by immunizing troops entering typhus areas and by protecting against louse infestations by personal hygiene measures and the use of issued insecticide powder.

d. **Miscellaneous Diseases.**

(1) Numerous other diseases of lesser importance--not because they are not seriously disabling, but because of a lower incidence--include the following:

(a) Schistosomiasis, caused by invasion of the bloodstream by a parasitic blood fluke, is a hazard in Africa, South America, the Caribbean, and the Orient. Larvae of the fluke can penetrate the skin of persons wading, swimming, or working in infested waters. The only means of prevention is avoiding infested waters.

(b) Rocky Mountain spotted fever, spread by the bite of certain ticks, is found in wooded and brushy areas of the United States, Canada, Mexico, Panama, Colombia, and Brazil.

(c) Scrub typhus, a disease occurring in eastern and southeastern Asia, northern Australia and adjacent islands, and India, is transmitted by the bite of mites living in vegetation.

(2) Preventive measures for these diseases include avoiding infested areas, where known and possible, use of individual insect repellent, and spraying campsites before occupying them. Over 75 known viruses transmitted by mosquitos, ticks, and flies have been implicated in causing encephalitides and fevers in man. Individual and unit preventive measures consist of eliminating mosquito and fly breeding places, use of protective netting, and the use of insecticides and repellents.

### **3-7. FOOD AND WATERBORNE DISEASES**

Because of the difficulty of preserving the sanitary quality of food, water, and utensils in the field, food and waterborne diseases constitute an ever-present hazard in combat or field operations.

a. **Foodborne Diseases.** Foodborne diseases may be classified as foodborne intoxication, chemical intoxication, and foodborne infections.

(1) Foodborne intoxication is caused by enterotoxins produced by certain microorganisms, of which staphylococci are the most important. Preventive measures include strict sanitation, exclusion from food service activities of all persons having staphylococcal infections, and prompt serving of foods at proper temperatures to preclude the growth of bacteria and the production of toxins. Botulism, another form of

foodborne intoxication, results from improperly canned or preserved foods of low acid content in which the causative agent grows and produces the toxin. Botulism is a relatively rare disease, but it has a high mortality rate when contracted. It is prevented by using canned and preserved foods only from approved sources.

(2) Chemical intoxication occurs when chemical contaminants enter the food. Chemical intoxication from metal contamination usually occurs when acid foods are prepared or stored in containers made of corrosive (usually plated) metal. The metallic salts formed by the reaction of the food with the metal leach into the food, causing chemical intoxication. This type of "poisoning" may be prevented by educating food service personnel in the proper storage and preparation of foods.

(3) Foodborne infections may be either bacterial or parasitic.

(a) Several common bacterial infections are salmonellosis (caused by Salmonella bacteria), Clostridium perfringens infection, and bacillary dysentery (shigellasis) caused by bacteria of the genus Shigella. Bacterial infections are caused by contaminating food (usually by unsanitary food practices) and allowing it to remain at temperatures favorable to bacterial growth. To prevent these diseases, food service personnel must practice strict sanitation in the handling of food, cleaning of food serving equipment, and storage of food at proper temperatures. The proper training of the individual soldier in the care and cleaning of his mess equipment plays an important role in preventing these diseases.

(b) There are three important parasitic infections of food--amoebic dysentery, trichinosis, and tapeworm. The former is caused by contamination of food or water with parasites (amoeba) found in infected human feces. Preventive measures are the same as for bacterial infections (see also para b below). The latter two diseases are caused by eating meat in which the living cysts of the Trichinella nematode (principally in pork) or tapeworm (in pork, beef, or fish) are present. Both may be effectively prevented by thoroughly cooking all meat.

b. **Waterborne Diseases.** These diseases include typhoid fever, paratyphoid fever, cholera, bacillary dysentery, amoebic dysentery, and infectious hepatitis. They may be acquired from drinking contaminated water. Food which has been prepared with such water and which has not been cooked sufficiently to kill the organisms will also cause these diseases. Prevention of these diseases depends upon the use of only potable water supplies for drinking and cooking and upon proper unit and individual water purification procedures when potable water supplies are not available.

### **3-8. SUPPORTIVE PREVENTIVE MEDICINE**

Unit-level preventive medicine, as we have seen, is accomplished by personnel whose qualifications do not exceed those of a company aidman or a field sanitation team. From time to time, situations may arise which require a higher level of professional or technical assistance to the unit commander. Such assistance is referred to as supportive preventive medicine.

a. **Battalion and Brigade Level.** At battalion (squadron) and brigade (group, division artillery) level, no preventive medicine personnel, as such, are assigned. However, the surgeon or physician's assistant can assist the unit commander by supervising company-level preventive medicine activities and by providing technical advice.

b. **Division Level.** When the battalion physician assistant or brigade surgeon needs assistance in preventive medicine matters, he can obtain specialized help from the preventive medicine section of the division medical battalion headquarters company. The section consists of a Medical Corps preventive medicine officer (SSI 60C), a Medical Service Corps environmental science officer (SSI 68N), an environmental health specialist NCO (MOS 91S40), and several additional enlisted medical specialists.

c. **Echelons Above Division Level.** Above division level, medical support in a theater of operations is provided by a medical group or brigade in the combat zone and by a medical command in the communications zone (COMMZ). The structure of each of these organizations is flexible, so as to permit the tailoring of each for the efficient command and control of the nondivisional medical units in the theater of operations. Both the medical brigade and the medical command normally include the following subordinate units, which provide backup preventive medicine services to the division or to separate units within an established area:

(1) A medical laboratory (TOE 8-650). The medical laboratory augments the capabilities of other preventive medicine units by performing tests in support of epidemiological studies.

(2) Veterinary cellular teams (TOE 8-680), which may be found anywhere in the combat zone or COMMZ, are responsible for much of the preventive medicine programs connected with zoonotic diseases and foodborne disease controls.

(3) Preventive medicine cellular teams (TOE 8-600 and 8-620). These teams are referred to as cellular teams because each is organized as a cell, or module, to perform a specific function. They may operate independently or in any combination of teams, as the situation dictates, under the control of a headquarters team or attached to a preventive medicine unit. Each team (except team LE) has a structure similar to one of the organizational elements of the preventive medicine unit and has a parallel function. The personnel of this section are technically qualified to train unit field sanitation teams to identify actual and potential health hazards and to recommend corrective measures.

## **Section II. PREVENTIVE MEDICINE ACTIVITIES IN FIXED INSTALLATIONS**

### **3-9. GENERAL**

The basic concept of preventive medicine in fixed installations does not differ from that in operational areas--that is, the commander is still responsible for the health

and safety of his command. However, within a fixed military installation, either overseas or in the continental United States (CONUS), the allocation of tasks is somewhat different and the emphasis shifts to other major areas.

a. **Corps of Engineer.** On a fixed installation, such responsibilities as water supply, sewage and refuse disposal, and repair and utilities are assumed by the Director of facilities engineering (DFAE). The DFAE may or may not also be a member of a tactical (such as a division or corps) staff. Director of facilities engineering also perform most insecticide spraying operations in conjunction with the installation preventive medicine section.

b. **Unit Field Sanitation Team.** The unit field sanitation team is not operational in garrison. It assumes a training role in preparation for its employment in the field.

c. **Installation Medical Support.** In fixed installations, medical support is rendered on an area rather than an organizational basis. Assigned unit medical personnel are normally pooled in post medical treatment facilities under the operational control of the director of health services (DHS). The DHS is a member of the installation commander's staff and is the commander of the US Army Medical Department Activity (MEDDAC) providing primary medical support to the installation (para (1) below). At installations provided medical support by a medical center (para (2) below), the center commander will appoint an appropriate individual to serve as DHS on the installation staff.

(1) Medical department activity. A medical department activity (MEDDAC) is a TDA organization under the jurisdiction of the Commander, US Army Health Services Command. Its mission is to exercise command and control over assigned and attached AMEDD units providing health services within its geographical area of responsibility. A MEDDAC is normally established at each installation having a US Army hospital or a US Army health clinic. The senior Medical Corps officer assigned to the hospital or health clinic commands the MEDDAC. When the MEDDAC does not have a US Army hospital, it includes additional elements normally included in the hospital.

(2) Medical center. An Army medical center differs from a US Army hospital in that it is especially staffed and equipped to afford facilities for the observation, treatment, and disposition of patients requiring relatively long periods of hospitalization or highly specialized treatment. A medical center performs the functions of a MEDDAC in providing area medical support to the installation on which it is located or to adjacent installations not having MEDDACs.

(3) United.States. Army Health Services Command. The US Army Health Services Command (HSC) is a major Army command under the jurisdiction of the Headquarters, Department of the Army, with headquarters at Fort Sam Houston, Texas. The Commander, HSC, commands all Army health service organizations, units, facilities, and activities in CONUS except TOE units and those activities controlled directly by The Surgeon General.



### **3-10. PREVENTIVE MEDICINE**

Preventive medicine activities on a fixed installation are conducted under the supervision of the Director of Health Services by a group of individuals known as the preventive medicine team. The members of the team are normally the personnel assigned to the preventive medicine activity of the MEDDAC or the preventive medicine activity of the supporting medical center.

**Continue with Exercises**

### EXERCISES, LESSON 3

**INSTRUCTIONS.** The following exercises are to be answered by marking the lettered response that best answers the question or best completes the incomplete statement or by writing the answer in the space provided.

After you have completed all the exercises, turn to, "Solutions to Exercises" at the end of the lesson and check your answers.

1. The primary source of preventive medicine assistance to the unit commander in the field is the \_\_\_\_\_.
2. Which of the following is a normal Corps of Engineers responsibility under field conditions?
  - a. Water supply.
  - b. Food service sanitation.
  - c. Immunizations.
  - d. Waste disposal.
3. The primary emphasis in field preventive medicine is on \_\_\_\_\_.
4. Which of the following diseases are usually considered to be of greater significance in the field than in garrison? (**NOTE:** More than one answer may be correct.)
  - a. Gonorrhea.
  - b. Malaria.
  - c. Tuberculosis.
  - d. Skin diseases.
  - e. Shigellosis.
  - f. Meningitis.

5. When preventive medicine problems are beyond the capability of the field sanitation team, the unit commander must request assistance from \_\_\_\_\_ preventive medicine resources.
6. The lowest organizational level at which specialized preventive medicine personnel are assigned is the \_\_\_\_\_
7. In fixed installations, water supply and waste disposal are responsibilities of the:
  - a. Director of Facilities and Engineering (DFAE).
  - b. Director of health services.
  - c. Field sanitation team.
  - d. Preventive medicine officer.
8. In garrison, the field sanitation team:
  - a. Performs essentially the same tasks as in the field.
  - b. Is disbanded.
  - c. Assists the DFAE.
  - d. Assumes a training role.

**Check Your Answers on Next Page**

## **SOLUTIONS TO EXERCISES, LESSON 3**

1. Field sanitation team. (para 3-2b)
2. a (para 3-3a(1))
3. Disease prevention. (para 3-4)
4. b (para 3-6a)  
d (para 3-5)  
e (paras 3-7a(3)(a))
5. Supportive. (para 3-8)
6. Division medical battalion. (para 3-8a)
7. a (para 3-9a)
8. d (para 3-9b)

**End of Lesson 3**

## LESSON ASSIGNMENT

### LESSON 4

Climatic Injury Control.

### LESSON ASSIGNMENT

Paragraphs 4-1 through 4-24.

### LESSON OBJECTIVES

After completing this lesson, you should be able to:

- 4-1. Recognize the clinical signs and symptoms of cold and heat injuries and select the appropriate aid measures for each.
- 4-2. Identify the environmental and host factors that are likely to result in heat or cold injury.
- 4-3. Use the wet bulb globe temperature (WBGT) index and the wind chill factor to predict the risk of heat or cold injury on a given day.
- 4-4. Identify the important elements of an effective program for the prevention of heat or cold injuries.

### SUGGESTION

After completing the assignment, complete the exercises at the end of this lesson. These exercises will help you to achieve the lesson objectives.

## LESSON 4

### CLIMATIC INJURY CONTROL

#### Section I. ENVIRONMENTAL COLD INJURIES

##### 4-1. INTRODUCTION

a. Cold injury is defined as tissue trauma produced by exposure to cold. The type of injury produced depends upon the degree of cold to which the body (or its parts) is exposed, the duration of exposure, and certain environmental factors. For practical purposes, cold injuries may be divided simply into "freezing" and "non-freezing" types. The former is the well-known frostbite (superficial or deep). The non-freezing types are chilblains, trench foot, and immersion foot. There exists no real justification for distinguishing between trench foot and immersion foot with respect to management, nor even to the environmental conditions that are causative. Both result from prolonged exposure of the feet to wet cold: trench foot to cold, wet socks and boots, immersion foot to cold water--with or without socks and boots. For present purposes, the term "trench foot" will be employed to cover both, "immersion foot," and the more cumbersome, "non-freezing cold injury." Chilblains is the only injury that is not of significant military importance.

b. Nonfreezing cold injuries may be defined as follows:

(1) Chilblains are swelling and reddening of the skin that usually result from intermittent exposure to temperatures above freezing, accompanied by high humidity.

(2) Trench foot and immersion foot result from a prolonged exposure to wet, cold foot gear or outright immersion of the feet at temperatures usually below 50°F. At the upper range of temperatures, exposure of 12 hours or more will cause injury. Shorter durations at or near 32°F will cause the same injury. It is usually associated with immobilization and dependency of the feet.

c. Frostbite results from exposure to temperatures below the freezing point. The depth and severity of the injury is a function of the temperature and the duration of exposure--the lower the temperature, the shorter the time required to produce injury. At very low temperatures, in the presence of wind, freezing of exposed skin can occur within a few seconds.

d. Cold injury occurs among the civilian population, but its primary impact is on the military forces. Cold injury has been recorded as a problem of military importance since the days of Xenophon, and Alexander of Macedonia. Larrey classically described the role which cold injury played in the defeat of Napoleon's Army in Poland in 1812.

The US had considerable experience with cold injury during World War II. In the US Army, there was a total incidence of 90,535 time--lost injuries that included trench foot and frostbite in ground troops and high altitude in aircrews. More recently, in Korea, US troops experienced more than 9,000 cases of cold injury, chiefly frostbite, in ground troops. Over 8,000 of these cases occurred in the winter of 1950-1951.

#### **4-2. ENVIRONMENTAL FACTORS**

Cold injury, as it involves a military population, behaves in general according to accepted epidemiologic principles. A specific agent is present and a variety of environmental and host factors influence the incidence, prevalence, type, and severity of the injury. These factors combine in the total causation of cold injury, and the influence of each may vary in every situation. Careful evaluation of these factors and their relative effects serves to guide preventative and control activities.

a. **The Agent.** Cold is the specific agent in cold injury and is the immediate cause of tissue damage. If, however, the effect of cold is considered to be loss of body heat, an agent relationship with modes of heat conduction and heat production is apparent, and the ways in which various host and environmental factors modify cold injury become clear. Therefore, the effect of cold cannot be evaluated by ambient (air) temperature alone.

b. **Weather.** Weather is a predominant influence in causing cold injury. Temperature, humidity, precipitation, and wind modify the rate of body heat loss. Low temperatures favor frostbite, whereas higher temperatures together with ground moisture are usually associated with trench foot. Wind velocity accelerates body heat loss under both wet and cold conditions. The wind chill effect is shown in table 4-1, and this effect must be thoroughly understood by all personnel in areas where cold injury is possible. It must be recognized also that the equivalent temperature depicted on the wind chill chart relates to the cooling effect on exposed skin and clothing. The specific implications of the wind-chill phenomenon then relate to a freezing hazard of unprotected body surfaces--face or ears. It is important also when considering host factors in general that increasing wind should be recognized as a significant factor in total body heat loss.

c. **Type of Combat Action.** The incidence of cold injury varies greatly according to type of combat action. Units in reserve or in rest areas have few cases; on holding missions or on static defense, exposure is greater and a moderate increase in incidence is expected; on active defense or offense, marked increases usually occur. Immobility under fire, prolonged exposure, lack of opportunity to rewarm and change clothing or carry out personal hygienic measures, fatigue, and state of nutrition may all be involved.

d. **Clothing.** In warfare, where exposure to cold may be prolonged, adequate clothing properly worn is essential to welfare and survival. Clothing for cold weather combat has been designed to be worn as an assembly for protection of the head, torso, and extremities. Failure to wear the total assembly and inadequate supplies of proper sizes of clothing are important factors in cold injury. The assembly depends upon the layering principle to conserve body heat. Loose layers of clothing with air space between them, under an outer wind and water-resistant garment, provide maximum protection. It is flexible in that inner layers may be removed for comfort and efficiency to minimize perspiration in higher ambient temperatures or during strenuous physical exertion. Clothing wet by perspiration loses much of its insulating value, and care must be taken to prevent perspiration from accumulating in the clothing. Moisture against the skin causes a very rapid decrease in temperature of the tissue and can lead to frostbite or hypothermia. In all forms of cold injury, prevention of loss of body heat is important. All articles of clothing must be loose, to avoid constriction and tightness. Clothing must be kept free of grease and dirt.

#### 4-3. HOST FACTORS

- a. **Age.** Within the usual age range of combat personnel, age is not significant.
- b. **Rank.** Trench foot and frostbite have a high selectivity for the frontline riflemen, and predominantly those of the lower ranks. The decreased incidence of cold injury among higher ranks is the reflection of a combination of factors, such as lesser degree of exposure, more experience, and greater receptivity to training.
- c. **Previous Cold Injury.** A previous episode of cold injury definitely increases the individual's risk of subsequent cold injury, not necessarily involving the part previously injured. However, minor degrees of superficial cold injury, when completely healed, probably do not predispose to subsequent injury sufficiently to require profiling or other restriction on assignment.
- d. **Fatigue.** Fatigue is a factor contributory to cold injury. Mental weariness may cause apathy leading to neglect of acts vital to survival. This occurs more frequently in personnel who have been in combat for 30 days or more without rest. Frequent rotation of troops from active combat duty for even short periods lessens the influence of the fatigue factor.
- e. **Concomitant Injury.** Experience has shown that injuries resulting in significant blood loss or shock reduce effective blood flow to extremities and predispose to cold injury.



f. **Discipline, Training, and Experience.** Proper use of simple preventive measures that are inspected and enforced by officers and noncommissioned officers will markedly reduce the incidence of cold injury. Individual and unit discipline, training and experience are closely related in their influence upon the incidence of cold injury. Well trained and disciplined men suffer less than others from the cold, as they are better able to care for themselves through personal hygiene, care of feet, change of clothing, exercise of the extremities when immobilized, and similar effective measures.

g. **Psychosocial Factors.** Cold injury tends to occur in passive, negativistic individuals, who tend to display little muscular activity and are prone to pay less attention to carrying extra footwear and changing socks when needed.

h. **Race.** In terms of numbers at risk, and independent of geographic origin, the Black appears to be considerably more vulnerable to frostbite than the Caucasian. This has been a consistent observation dating from World War II through Korea and into the present in Alaska. It suggests that the Black must be particularly vigilant in hand and foot care during cold exposure.

i. **Geographic Origin.** Caucasian personnel from warmer climates in the US (where the mean minimum January temperature is above 20°F) appear to be predisposed to cold injury. The basic factor involved, however, is considered to be psychosocial and educational, rather than geographic.

j. **Nutrition.** Starvation or semi-starvation predisposes to cold injury. Adequately clothed and protected personnel in cold climates do not require more than the normally provided military ration of 3600-4600 calories. Evidence of a need for specific nutrients in the diet for cold injury prevention or treatment is lacking.

k. **Activity.** Too great or too little activity may contribute to cold injury. Over activity can cause the loss of large amounts of body heat by perspiration, which becomes trapped in excess clothing, markedly reducing the insulation quality of the clothing. Conversely, immobility causes decreased heat production with the danger of resultant cooling, especially of extremities and pressure areas of the body.

l. **Drugs and Medication.** Physicians should advise patients of any adverse effects on peripheral circulation or sweating when prescribing drugs and medications in cold climates. Morphine is an important example of a drug with a significant effect on blood circulation and therefore on body heat balance.

m. **Alcohol.** Because of its questionable vascular effects, coupled with its influence on judgment, alcohol should be avoided under conditions of extreme cold. The dangers of excessive lowering of body temperature (hypothermia) and frostbite are increased greatly under its influence.

#### 4-4. DURATION OF EXPOSURE

a. The duration of exposure resulting in immersion foot varies according to the ambient (air) temperature of the water and, therefore, with season and latitude. Immersion of the torso and extremities in water below 50°F, as in northern latitudes, may result in death in less than one hour due to excessive lowering of body temperature (hypothermia).

b. The average duration of exposure resulting in trench foot is three days at a temperature range of 32° to 50°F with a time range of from a few hours to 14 days.

c. The average duration of exposure resulting in frostbite is 10 hours, with a usual range of 1 to 20 hours, but this varies for different types of activity. For patrols and other offensive maneuvers, the period of greatest susceptibility usually begins at that time when walking ceases either because of arrival at an ambush site or because of being pinned down by the enemy. In stationary guard situations, the same can be said for the time of posting of the guards; in vehicular movements, for the time of mounting; and in defensive maneuvers (fox holes), for the time immobilization begins. A decrease in physical activity reduces the exposure time necessary to produce cold injury

#### 4-5. SYMPTOMS

a. **Symptoms and Signs During Exposure.** The lack of warning symptoms emphasizes the insidious nature of cold injury, which unfortunately, is casually overlooked by many troops and commanders. The only warning symptoms may be tingling, stinging, or at most a dull aching sensation of the exposed part followed by numbness. The skin briefly may appear red and then becomes pale or waxy white. At this stage, the affected part may feel "like a block of wood." If freezing has occurred, the tissue appears "dead white," and is hard or even brittle, with complete lack of sensation and movement. Medical personnel rarely see these stages of cold injury, as thawing or rewarming with the development of the manifestation of the injury has usually occurred. Data from previous wars indicate that medical officers saw less than two percent of cold injury casualties before rewarming had occurred.

b. **Differentiation.** The differentiation of types of cold injury, that is, freezing vs. nonfreezing, may be difficult early after rewarming has occurred. The classification into trench foot, immersion foot, and frostbite is of use chiefly as a description of the mode of injury. Tissue injury is largely the result of blood vessel damage and hence will be similar in all forms of cold injury, the major variable being the severity. The type of cold injury usually encountered is a graded injury, which may involve superficial and deep frostbite. The actual severity of the injury cannot be accurately evaluated at this time.

## 4-6. PREVENTION

a. **Cold Injuries are Preventable.** Successful prevention requires vigorous command leadership and proper use of preventive measures that are inspected and enforced. Prior planning, cold weather training, and the provision of proper clothing and equipment are paramount. Specific preventive measures are directed toward conservation of total body heat and avoiding unnecessary prolonged exposure of personnel to cold, moisture, and activities favoring cold injury.

b. **Meteorological Data.** All commanders should be familiar with the utilization of simple weather data such as humidity, temperature, wind, and ground surface conditions that influence the risk of cold injury. Some weather conditions will require shortening of the exposure time of individuals engaged in patrols, guard, or motor movements in unheated vehicles, despite the adequacy of their clothing and equipment. These can frequently be anticipated by using weather data to predict the hazard for the next 12-hour period. Thus, clothing may be provided for the anticipated weather conditions and the periods of exposure shortened, if indicated.

c. **Cold Injury Control Officer.** Each platoon or comparable-sized unit should have a cold injury control officer or noncommissioned officer, who should be carefully selected on the basis of leadership, interest, and ability to supervise others in simple but constant preventive activities. Frequent observation of his men for early signs and symptoms of cold injury is of the utmost importance. He should check his men daily for good personal hygiene--especially of the feet, where a change of socks at appropriate intervals, along with a reasonable effort to keep them clean and dry, is essential. He should likewise encourage efforts to perform warming exercises and to avoid constriction of the extremities by clothing and footgear, and to avoid undesirable dependency of parts during rest periods of unavoidable immobility.

d. **The Buddy System.** Members of squads and patrols should be taught to observe their companions for evidence of cold injury. If sudden blanching of the skin is noted promptly, immediate care will usually prevent the development of a more serious cold injury. Holding (not rubbing) a warm hand on the blanched area of an ear, nose, or cheek until a normal color has been restored will be adequate rewarming. The part must then be protected against further exposure to cold. Fingers can be warmed against the skin of the abdomen or the armpit. Toes can be rewarmed by holding them against a companion's chest or abdomen under his outer clothing. A fairly reliable symptom of early frostbite of fingers and toes is the sudden loss of the sensation of cold or discomfort in the part. This is often followed by a pleasant feeling of warmth. If these danger signals are instantly heeded, cold injury can be prevented.

#### e. **Clothing.**

(1) A standard number of layers of clothing cannot be prescribed for universal wear throughout winter. Flexibility must be provided for local conditions. Certain basic principles are important, including the ventilation of the body during physical activity, the cleanliness and repair of clothing to prevent loss of insulation, and the avoidance of constriction produced by snug fitting socks, boots, underwear, sweaters, jackets, and trousers.

(2) Ground forces personnel in cold areas must be equipped with the insulated rubber combat boots. Frequent change of socks is important with these boots because of increased sweating and retention of sweat, followed by a lowered resistance to immersion foot. Although sweating in these boots does not contribute to the loss of insulation, it nevertheless leads to the softening of the soles of the feet by the retained sweat. Damage to tissues, produced by walking, results in a loss of skin from the soles of the feet which may require hospitalization. Cold injuries to the foot have been reported when wearing this insulated boot. These injuries usually result from inactivity and dependency of the foot, as occurs with prolonged sitting or standing without frequent foot or leg movement.

(3) In all types of footgear, feet perspire more than other parts of the body. Moisture accumulates in socks, decreasing their insulating quality. Because of this, special foot and sock care is essential. Extra socks should be carried by all personnel. Socks damp from perspiration will dry if carried unfolded inside the shirt. They should be changed at least daily and washed whenever the opportunity permits. Socks and other clothing soiled with dirt, grease, or salt from perspiration will conduct heat more rapidly, thus affording less protection against the cold.

#### f. **Guidelines in Use of Clothing.**

(1) When working, remove excess layers of clothing before perspiration starts, so that clothing does not become wet. Avoid wetting clothing or footgear, since moisture causes a dramatic loss of insulating quality.

(2) Wear clothing and footgear loose enough to permit layers of air to provide good insulation and to permit good circulation of blood to all parts of the body. Avoid tight-fitting uniforms.

(3) Keep hands well protected; mittens are more protective than gloves. Glove or mitten inserts that become wet should be removed and dried, or exchanged for dry inserts as quickly as possible. Avoid lengthy exposure of bare hands and wrists that will cause stiffening and reduce circulation, since it takes a long time to recondition the hands to normal use. **DO NOT TOUCH METAL, SNOW, OR OTHER COLD OBJECTS WITH BARE HANDS. DO NOT SPILL GASOLINE ON SKIN OR CLOTHING.**

(4) Remove excess clothing when in a warm enclosure or in front of a fire to avoid sweating.

#### **4-7. TREATMENT**

Treatment of cold injury depends upon the time elapsed after the injury, the severity of the injury, the presence of complications, and the area affected. In military operations, treatment will be influenced by the tactical situation, as well as by the facilities available for the evacuation of casualties. Most cold injuries appear en masse, during periods of intense combat, and at the time that large numbers of casualties occur. The examination and treatment of life-endangering wounds must take precedence over cold injuries. Highly individualized treatment is difficult during military operations, because of the large numbers of patients who require treatment almost simultaneously. The treatment of cold injury is divided into first aid, initial or emergency medical treatment in forward areas, and definitive treatment after the patient has reached a hospital. Since the latter two stages of treatment are conducted only by qualified medical personnel, we shall discuss only first aid at this point. Prevent further exposure to cold or at least shelter the patient from wind and cover the affected area. Rewarming is accomplished promptly by body heat such as by putting cold-injured hands into armpits under the clothing. If location of the injury prohibits use of patient's own body, use body of another cold-injury victim or someone else. If cold injury occurs, the patient should be restricted from his usual duties or activities until the severity of injury can be evaluated. All constricting items of clothing such as boots, socks, or gloves should be removed from the site of injury. The injured area must then be protected from further cold injury by blankets or any available clothing that is not constricting. Smoking, drinking of alcohol, and the application of medications, salves, or ointments are prohibited. Blisters must not be opened. Drinking hot liquids is encouraged, if available. If the lower extremity is involved, treat the victim as a litter patient with the part level or slightly elevated. In unusual circumstances, where travel on foot is the only means of evacuation for frostbite of the feet, thawing of the injured area is not indicated until the patient reaches an aid station and medical help. DO NOT allow an injury that has thawed to refreeze, as the resultant injury can be quite severe.

#### **4-8. THE WIND CHILL CHART**

The human body is continually producing and losing heat. Wind increases the loss of heat by removing the thin layer of warm air next to the skin. This loss increases as the wind speed increases. When the temperature of the air is below freezing and the wind removes the heat faster than the body can replace it, frostbite may occur. Thus, decreasing the ambient (air) temperature or increasing the wind speed acts to increase the danger of frostbite to exposed skin. The combined effect of wind and temperature is expressed in the wind chill chart (Table 4-1) as an equivalent temperature.

| <b>WIND CHILL CHART</b>                       |  |     |     |                             |     |     |     |                           |      |      |      |  |
|---|--|-----|-----|-----------------------------|-----|-----|-----|---------------------------|------|------|------|--|
| <b>LOCAL TEMPERATURE (°F)</b>                 |  |     |     |                             |     |     |     |                           |      |      |      |  |
|   | 32   | 23  | 14  | 5                           | -4  | -13 | -22 | -31                       | -40  | -49  | -58  |  |
| <b>Wind Speed (MPH)</b>                       | <b>EQUIVALENT TEMPERATURE (°F)</b>                 |     |     |                             |     |     |     |                           |      |      |      |  |
| <b>CALM</b>                                   | 32   | 23  | 14  | 5                           | -4  | -13 | -22 | -31                       | -40  | -49  | -58  |  |
| 5   | 29   | 20  | 10  | 1                           | -9  | -18 | -28 | -37                       | -47  | -56  | -65  |  |
| 10  | 18   | 7   | -4  | -15                         | -26 | -37 | -48 | -59                       | -70  | -81  | -91  |  |
| 15  | 13   | -1  | -13 | -25                         | -7  | -49 | -61 | -73                       | -85  | -97  | -109 |  |
| 20  | 7  | -6  | -19 | -32                         | -44 | -57 | -70 | -83                       | -96  | -109 | -121 |  |
| 25  | 3  | -10 | -24 | -37                         | -50 | -64 | -77 | -90                       | -104 | -117 | -117 |  |
| 30  | 1  | -13 | -27 | -41                         | -54 | -68 | -82 | -97                       | -109 | -123 | -137 |  |
| 35  | -1   | -15 | -29 | -43                         | -57 | -71 | -85 | -99                       | -113 | -127 | -142 |  |
| 40  | -3   | -17 | -31 | -45                         | -59 | -74 | -87 | -102                      | -116 | -131 | -145 |  |
| 45  | -3   | -18 | -32 | -46                         | -61 | -75 | -89 | -104                      | -118 | -132 | -147 |  |
| 50  | -4   | -18 | -33 | -47                         | -62 | -76 | -91 | -105                      | -120 | -134 | -148 |  |
|   | <b>LITTLE DANGER FOR PROPERLY CLOTHED PERSONS*</b> |     |     | <b>CONSIDERABLE DANGER*</b> |     |     |     | <b>VERY GREAT DANGER*</b> |      |      |      |  |
| <b>*DANGER FROM FREEZING OF EXPOSED FLESH</b> |  |     |     |                             |     |     |     |                           |      |      |      |  |

Table 4-1. Wind chill chart.

## Section II. ENVIRONMENTAL HEAT INJURIES

### 4-9. INTRODUCTION

Prevention of heat injury is a command responsibility and function. The staff surgeon is responsible for recommending the initiation of measures to safeguard health and for supervision of the execution of these measures. In the recent past, a battalion arrived at Qui Nhon, Vietnam, after 18 days on shipboard. The men were brought into an area of inadequate water and shade, and they began to work as if at their home station. In the first 72 hours, approximately 100 men were treated for heat prostration and a few for heatstroke. The situation was especially bad because medical supplies had not been unloaded first and no salt was available. Knowledge and proper planning would have prevented these casualties.

### 4-10. ENVIRONMENTAL AND PHYSIOLOGICAL FACTORS

a. Exposure to high environmental temperature produces stress on the body that may lead to illness and disability. The conditions in the environment that influence the heat of the body and its adjustments are the temperatures of the air, the temperature of the surrounding objects, the vapor pressure of the water in the air (relative humidity), the air movement, and the type and amount of clothing worn. The body loses heat by conduction and convection, by radiation, and by evaporation. Heat

loss by conduction to the air occurs where the air temperature is below body temperature. Conversely, heat gain by conduction occurs when air temperatures exceeds that of the body. Similarly, the body loses heat by radiation when the surrounding objects have surface temperatures lower than the temperature of the body surface, and gains heat by radiation when the temperature of surrounding surfaces is above that of the body surface. Accordingly, temperature combinations of the air and the surrounding objects may exist which result in heat gain by the body due to radiation, even though the air temperature is below that of the body. The enlargement of blood vessels in the skin and an increase in the rate of the heartbeat are normal body responses to heat stress. While these adjustments increase the temperature of the skin and thus increase heat loss by conduction and radiation, they place a strain on the circulatory system. These factors play important roles in the cause of heat stress reactions.

b. When the body cannot lose sufficient heat by conduction and radiation, the activity of the sweat glands increases, and heat loss by evaporation of sweat becomes the important means of maintaining normal body temperature. However, as the relative humidity of the air increases, evaporation of sweat decreases, thus reducing the cooling function of the sweat. Excess sweating may lead to a marked loss of water and salt from the body. The resulting dehydration and loss of body salt add to the stress on the circulatory system.

c. Other major factors influencing physiologic responses incident to high temperature exposures relate to the physical work performed prior to and during the exposure, and the physical condition of the individual. The body is continually producing heat, but during physical work, the production of heat is increased in proportion to the type, intensity, and duration of the work. Thus, physical work accentuates the effects of high temperature. Individual susceptibility to heat stress may be increased by a large number and variety of conditions, including acute and chronic infections, febrile conditions, reactions to immunizations, conditions affecting sweat secretion, heat rash or acute sunburn, previous occurrence of heatstroke, use of alcohol, dehydration, lack of sleep, fatigue, and obesity. The risk of heat injury is very much higher in overweight persons than in those of normal weight, and special care should be exercised when such persons are exposed to high temperatures.

d. The temperature of the human body is regulated within extremely narrow limits, although there may be marked variations in the environmental heat. Three fairly distinct types of heat injury may occur, depending upon the manner of breakdown of the individual's heat adjustment. These injuries are heat cramps, heat exhaustion, and heatstroke. The three conditions produce distinctive signs and symptoms that should be recognized at once--not only by AMEDD personnel, but also by unit personnel--if the victim is to receive proper care and attention. All military personnel in the field should be familiar with first-aid treatment of these conditions.

#### 4-11. HEAT CRAMPS

a. **Symptoms.** Painful cramps of the muscles may occur following exposure to heat. Heat cramps result primarily from excessive loss of salt from the body. The muscles of the extremities and of the abdominal wall are usually involved and the cramps may be of great severity. Body temperature is normal.

b. **Treatment.** Heat cramps are promptly relieved by replacing the salt lost from the body. In the field situation, the patient should drink at least 250 cc of water (1/4 canteen), take two 10 grain (648 mg) salt tablets, followed by the rest of the water in the canteen. In the absence of salt tablets, add other source of salt, such as adding C-ration salt to any food or beverage is acceptable. If salt is added to a beverage or water, it should not exceed 0.1 percent strength, as noted in Table 4-2.

| SALT                                | DILUTING WATER           |
|-------------------------------------|--------------------------|
| 2 ten-grain salt tablets            | 1 quart canteen          |
| 4 ten-grain salt tablets            | 2 quart canteen          |
| 1 1/3 level mess kit spoons of salt | 5 gallon can             |
| 9 level mess kit spoons of salt     | Lyster bag               |
| 1 level canteen cup of salt         | 250-gallon water trailer |

Table 4-2. Preparation of 0.1 percent salt solution.

#### 4-12. HEAT EXHAUSTION

Heat exhaustion results from excessive loss of water from the body (with inadequate fluid replacement), resulting in decreased blood volume. Salt depletion is often present, but not always. The condition is characterized by heavy sweating, pallor of the skin, low blood pressure, and other indications of collapse of the circulatory system. The mortality rate from this disorder is extremely low, and as a rule, the removal of the patient to a cool environment, rest, and the administration of salt solution will result in prompt recovery.

a. **Clinical Picture.** Heat exhaustion is manifested by weakness, dizziness, faintness (especially on standing) and other symptoms such as nausea and muscle cramps may also be present. Occasionally, cramps of the extremities or abdominal muscles occur. Consciousness is rarely lost. The mouth temperature may be below normal or slightly elevated, but the rectal temperature is usually elevated (99° to 101°). The skin is usually cool, and there is profuse perspiration. The pulse rate is rapid (140 to 200 per minute), and the blood pressure may be lowered.



b. **Treatment.** The patient should drink at least one canteen of water. Salt replacement (as for heat cramps) is also advisable if he has been perspiring heavily and has had poor salt intake. He should lie down with feet higher than the level of his chest, preferably in a cool place, until his symptoms have improved. If he cannot take oral fluids, intravenous fluids such as saline solution are needed and he should be evacuated to a MTF. If water is not available, salt tablets or salt in other forms should not be administered alone.

#### 4-13. HEATSTROKE (Sunstroke)

Heatstroke is a medical emergency. It is characterized by extremely high body temperature, usually with coma. The development of heatstroke represents a breakdown of the body's heat regulating mechanism and is particularly prone to occur in individuals who are not acclimatized to heat. Physical exertion, immunizations, and infections may predispose to the development of heatstroke. After the disturbance of the heat regulating mechanism occurs, the individual may absorb heat from the ground or the surrounding air. Of great importance is the absence of sweating. During the early stages of this condition, after sweating has stopped and the temperature has risen, the individual may be exhilarated and unaware of the dangerous condition that is developing. All military personnel should be taught the importance of the recognition of cessation of sweating and the initiation of corrective measures at the stage when the condition is reversible. It is important to note that it is possible for a patient with heatstroke to have some sweating. If he has the other signs, mental changes, and high body temperature, he should be treated for heatstroke.

a. **Clinical Picture.** There may be early symptoms of headache, dizziness, mental confusion, weakness, nausea, urination, and diminished or absent sweating. Usually, however, the onset of heatstroke occurs with dramatic suddenness, with collapse and loss of consciousness. Deep coma is usually present and convulsions may occur. In the early stage, the patient's skin is usually hot, red, and dry; there is usually an absence of sweating. The pulse is full and rapid, and the blood pressure is normal or elevated. Respirations are rapid and deep. The body temperature is usually markedly elevated (100°F to 104°F). As the patient's condition worsens, cyanosis is usually noted together with a rapid pulse and lowered blood pressure. The breathing becomes shallow and irregular. Death may ensue very rapidly, but if the patient survives until the second day, recovery usually occurs. Rectal temperatures of 102° to 103°F may persist for several days, during which time mental disturbances, excitement, and delirium may continue or recur. Headache may persist for several weeks after the attack. In the first few days after the temperature has been reduced from a critical level, severe relapses may occur. The patient should, therefore, be observed carefully during this period, and rectal temperatures should be recorded frequently. Treatment, as outlined below, should be started again at the first indication of relapse. It is also important to emphasize that the heat regulating centers may be extremely unstable for many weeks after an attack. One attack of heatstroke predisposes to future attacks, and care should be taken by the individual to avoid a second exposure to the precipitating condition.

b. **Treatment.** The lowering of the patient's body temperature as rapidly as possible is the most important objective in the treatment of heatstroke. The longer the temperature remains elevated, the greater of threat to life. Measures to lower the individual's body temperature should be initiated at the earliest possible moment. In the field, the patient's clothes should be removed. If there is any source of cool water nearby, the patient should be immersed in water, or otherwise it should be sprinkled over the patient and its evaporation hastened by fanning. In addition to these cooling measures, the attendants should rub the patient's extremities and trunk briskly to increase circulation to the skin. The patient should be removed to a hospital immediately, and measures to cool the body should be continued until the hospital is reached. During transportation, the skin should be kept moist; the passage of air currents through the opened door of an ambulance will aid cooling. If ice bags (including the chemical ice bags) are available placing at least two at the neck and/or axilla will be helpful. When the patient reaches the hospital, further cooling measures should be carried out immediately by placing him in a tub of water and ice. Continuous massage of the patient's extremities should be carried out to promote vasodilation and heat loss. After the rectal temperature is reduced to 102°F, the patient should be removed to a bed and the temperature taken every 10 minutes. Details of hospital management of these patients are not included in this publication because these seriously ill patients may develop various complications. Their management should be by physicians.

#### **4-14. PREVENTION OF ADVERSE EFFECTS OF HEAT**

Successful prevention of adverse effects of heat depends largely on education of personnel, both those exposed to heat, and especially those charged with the supervision of such personnel. Specifically, prevention of heat injury involves the application of measures for increasing the resistance of exposed persons and reducing the exposure as much as practicable. Resistance is increased by replenishing water and salt losses from the body as they occur, by gradual acclimatization of individuals to hot environments, and by the maintenance of the optimum physical condition of personnel. Heat stress is decreased by reducing the workload and by introducing any measure that will protect the individual from the hot environment. Each of these measures is discussed briefly in the following paragraphs.

#### **4-15. WATER**

a. The human body is highly dependent on water to cool itself in a hot environment. Evaporating heat is the primary means the body utilizes for cooling. An individual subjected to high heat stress may lose water well in excess of one quart per hour by sweating. Water losses must be replaced or else rapid decrease in the ability to work, rise in body temperature and heat rate, deterioration of morale, and heat exhaustion will occur. Water loss should be replaced preferably by periodic intake of adequate amounts of water through the work period. Table 4-3 may be used as a guide to estimate the drinking water requirements for personnel exposed to heat stress. During the period of moderate activity, with moderate conditions prevailing, water

requirements will be one pint or more per hour per man. This is best taken at 20- to 30-minute intervals. As activities or conditions become more severe, the intake increases accordingly. When water is in short supply, significant water economy may be achieved by limiting physical activity to the early morning, evening, and night hours when the heat load is less and sweating is reduced. The optimum temperatures of water for drinking is 60°F ± 10°.

b. The belief that men can be taught to adjust to decreased water intake is incorrect.

|   |  | Quarts per man per day for drinking purposes (a guide for planning only) WBGT or WB index*. |                  |
|---|--|---|------------------|
| ACTIVITY  | ILLUSTRATIVE   | Less than 80°   | Greater than 80° |
| Light   | Desk   | 6   | 10               |
| Moderate  | Route march  | 7   | 11               |
| Heavy   | Forced marches, stevedoring, entrenching, or route marches with heavy loads or in CBR protective clothing. | 9   | 13               |
| * 80° WBGT or WD index is approximately equivalent to a dry bulb temperature of 85° in a jungle or 105° in a desert environment |  |   |                  |

Table 4-3. Water requirements.

#### 4-16. SALT

While significant quantities of sodium chloride may be lost by sweating, no special salt supplements are routinely required as a heat injury countermeasure. The quantity of salt normally consumed with meals will satisfy most requirements. Individuals should be cautioned against self-administered salt supplements (that is, salt tablets) as salt overload in the digestive tract quite commonly causes gastrointestinal illness which may result in vomiting, dehydration, and electrolyte imbalance.

#### 4-17. ACCLIMATIZATION

a. Training programs for personnel who are unseasoned to heat should be limited in intensity and time. A period of approximately 2 weeks should be allowed for acclimatization with progressive degrees of heat exposure and physical exertion. If men are required to perform heavy physical work before being properly acclimatized, the work is poorly performed, development of the capacity to work effectively is retarded,

and the risk of heat injury and disability is high. A period of acclimatization is necessary regardless of the individual's physical condition, although the better the physical condition, the quicker acclimatization is completed.

b. Acclimatization to heat begins with the first exposure and is about 80% developed by the end of the second week. Individuals who are unusually susceptible to heat will require additional time for acclimatization. Full acclimatization (the ability to perform a maximum amount of strenuous work in the heat) is attained most quickly by graded, progressively increasing work in the heat. Resting for 3 or 4 days in the heat, with activity limited to that required for existence, results in definite but only partial acclimatization. Physical work must be accomplished but should be limited to brief periods. A day or two of intervening cool weather will not interfere significantly with acclimatization.

c. A schedule should be established which provides for alternating work and rest periods. Although advantage should be taken of the cooler hours in accomplishing a portion of the work, the schedule should include gradually increasing exposure during the hotter parts of the day rather than complete exclusion of work at that time. The work period should be divided so that a man works and rests in alternating periods. When necessary for the accomplishment of a given task, two details can be arranged to work in sequence.

d. Adequate water must be provided at all times.

e. Once acclimatized, the soldier will retain his adaptation for about 2 weeks after leaving the hot environment. But if he is not exposed to high temperatures thereafter, the acclimatization will then decrease at a variable rate, the major portion usually being lost within one month.

f. Acclimatization to a hot, dry (desert) environment increases markedly the ability of men to work in hot, moist (jungle) environment; however, for proper acclimatization to the latter, residence with regulated physical activity is required. While carefully and fully developed acclimatization increases resistance, it does not confer complete protection against ill effects of heat.

g. Under conditions of heat stress, meals should be cool rather than hot. The heaviest meal should be served in the evening rather than at noon. An hour of rest following the noon meal is beneficial.

#### **4-18. WORK SCHEDULES**

Work schedules must be tailored to fit the climate, the physical condition of personnel, and the military situation. Close supervision by medical officers, responsible commanders, and experienced paramedical personnel is essential in achieving maximum work output with minimum hazard. Certain general principles must be considered.

- a. The amount of heat produced by the body increases directly with increasing work. Therefore, reduction of workload markedly decreases the total heat stress.
- b. Workloads and/or duration of physical exertion should be less during the first days of exposure to heat and should be gradually increased to allow acclimatization.
- c. While decisions to modify work schedules must be governed by the particular local situation, heavy work should be scheduled for the cooler hours of the day, such as early morning or late evening.
- d. Alternate work and rest periods may prove desirable. Under moderately hot conditions, 5-minute rest periods in the shade alternating with 25 minutes of work in the sun may be desirable. Under severe conditions, the duration of rest periods should be increased.
- e. Exposure to high temperature at night as well as in the daytime will decrease the amount of work men can perform effectively.
- f. Workloads must be reduced at high temperatures when dehydration resulting from excess sweating and lack of water replacement occurs. When water is in short supply, working in the early morning and evenings will allow much more work to be accomplished for the expenditure of a given amount of water than working during the hottest hours of the day.
- g. Work in the direct sun should be avoided as far as possible on hot days.
- h. Unnecessary standing at attention in the heat should be avoided, because continued standing places an added burden on the circulation.
- i. When the temperature is excessively high, physical work should be curtailed or, under extremely severe conditions, even suspended. The temperature at which work should be curtailed or suspended depends on the humidity, heat radiation, air movement, character of the work, degree of acclimatization of personnel, and other factors. Heat casualties may be expected at wet bulb temperatures of 75°F and above unless preventive measures are instituted. Overexertion can cause heat injury at even lower temperatures.

#### **4-19. PROTECTION FROM THE ENVIRONMENT**

Except when exposed to the sun's rays, an individual in a hot environment is better off wearing the least allowable amount of clothing. Clothing reduces the exposure of the body surface to solar radiation but to get that advantage of its benefits and minimize its disadvantage, clothing should be loose fitting---especially at neck, wrists, and lower legs--to allow circulation of air. Protection from the environment also includes such simple but frequently overlooked things as marching troops over grass rather than concrete and operating in as much shade as is available.

#### **4-20. SPECIAL CONSIDERATIONS IN RECRUIT TRAINING**

a. Basic trainees comprise a special group of unseasoned personnel who require particular attention because of the unusual physical stress involved in basic training in summer heat. Adjustment to this stress is difficult and must be taken into account in planning training schedules. Curtailment of work and scheduling strenuous training activities for the coolest parts of the day will yield greater efficiency and less disruption of training than will ignoring the weather in the interest of completing a heavy schedule. Heat casualties occur most frequently during the first 2 weeks of basic training and during bivouac week. They are associated especially with firing on the rifle range, road marches, and retreat parades. Particular attention should be paid to decreasing the heat stress accompanying these activities.

b. Recruit heat casualties tend to occur in groups within particular units. Responsible commanders and medical officers should therefore, promptly investigate each case to determine the unsafe practice or condition responsible and institute measures to prevent additional cases.

#### **4-21. EVALUATING THE ENVIRONMENT**

Three basic factors that determine the degree of heat stress exerted by the environment are air temperature, relative humidity and air movement, and heat radiation.

a. The air temperature is read from the ordinary dry bulb thermometer. The thermometer should be in the shade, so that the reading is affected only by the air temperature.

b. The relative humidity and air movement is determined by the wet bulb temperature. The wet bulb temperature is the reading of a thermometer when the bulb is covered with a wet wick and when a strong current of air is passed over the wick. The amount of heat lost by the bulb under these conditions, and thus reading of the thermometer, is affected by both temperatures and humidity. The wet bulb temperature is always below the dry bulb temperature except when the relative humidity is 100 percent, at which point both temperatures are equal.

c. The radiant heat can be determined by a black "globe" thermometer or by a radiometer. The globe thermometer, which is the simpler instrument, consist of a 6-inch hollow copper sphere painted flat black, with an ordinary thermometer inserted so that the temperature at the center of the sphere can be recorded.

d. Because of the difficulty in recording all three of these measurements and combining the readings into a single index as a measure of overall heat stress for man, usually only the dry and wet bulb temperatures have been used. The dry bulb temperature is, in general, a poor indication of thermal stress because it is not affected by humidity, air movement, or radiation. The wet bulb temperature is a better index

since it includes the humidity factor as well as the air temperature. For example, work that is relatively easy at a dry bulb temperature of 95°F with a relative humidity of 50 percent (80°F wet bulb) becomes impossible at the same dry bulb temperature when the relative humidity approaches 100 percent (96°F wet bulb). At a given wet bulb temperature, the dry bulb temperature can vary upward over a wide range without much physiological effect on an individual. However, the wet bulb temperature is not a good index of the heat stress imposed upon individuals exposed to the sun. Air movement also is not taken into account in these measurements. Many attempts have been made to devise a single index combining all four of these factors which is simple and can be used without elaborate equipment or training of personnel. Investigations suggest that the WBGT index provides such a standard, as does the more portable Botspill.

#### 4-22. WET BULB GLOBE TEMPERATURE INDEX

a. The WBGT index is computed from readings of (1) a stationary wet bulb thermometer exposed to the sun and to the prevailing wind, (2) a black globe thermometer similarly exposed, and (3) a dry bulb thermometer shielded from the direct rays of the sun. All readings are taken at a location representative of the conditions to which men are exposed. The wet bulb and globe thermometers are suspended in the sun at a height of 4 feet above ground (figure 4-1) for at least 20 minutes before readings are taken.

b. The wet bulb thermometer is a standard laboratory glass thermometer with its bulb covered with a wick (heavy white corset or shoe-string). The wick is dipped into a flask of clean, preferably distilled, water. The mouth of the flask should be about three-fourths of an inch below the tip of the thermometer bulb. The water level in the flask should be high enough to ensure thorough wetting of the wick. The water should be changed daily after rinsing out the flask and washing the wick with soap and water. To avoid erroneous readings, the water and wick must be free of all salts and soap.

c. The globe-thermometer apparatus consists of a 6-inch hollow copper sphere painted flat black on the outside and containing a thermometer with its bulb at the center of the sphere. The thermometer stem protrudes to the outside through a rubber stopper tightly fitting into a brass tube soldered to the sphere (figure 4-1). The sphere has two small holes near the top used for suspending the sphere with wire or strong cords. The globe must be kept dull black at all times and free of dust or rain streaks, by dusting, washing, or repainting if necessary.

d. The WBGT Index is computed as follows:

$$\begin{aligned} \text{WBGT} &= 0.7 \times \text{wet bulb temperature} \\ &+ 0.2 \times \text{black globe temperature} \\ &+ 0.1 \times \text{dry bulb temperature (shade)} \end{aligned}$$

|          |                        |             |              |
|----------|------------------------|-------------|--------------|
| Example: | wet bulb temperature   | 80°F x 0.7  | = 56°F       |
|          | black bulb temperature | 105°F x 0.2 | = 21°F       |
|          | dry bulb temperature   | 90°F x 0.1  | = <u>9°F</u> |
|          |                        | WBGT Index  | = 86°F       |

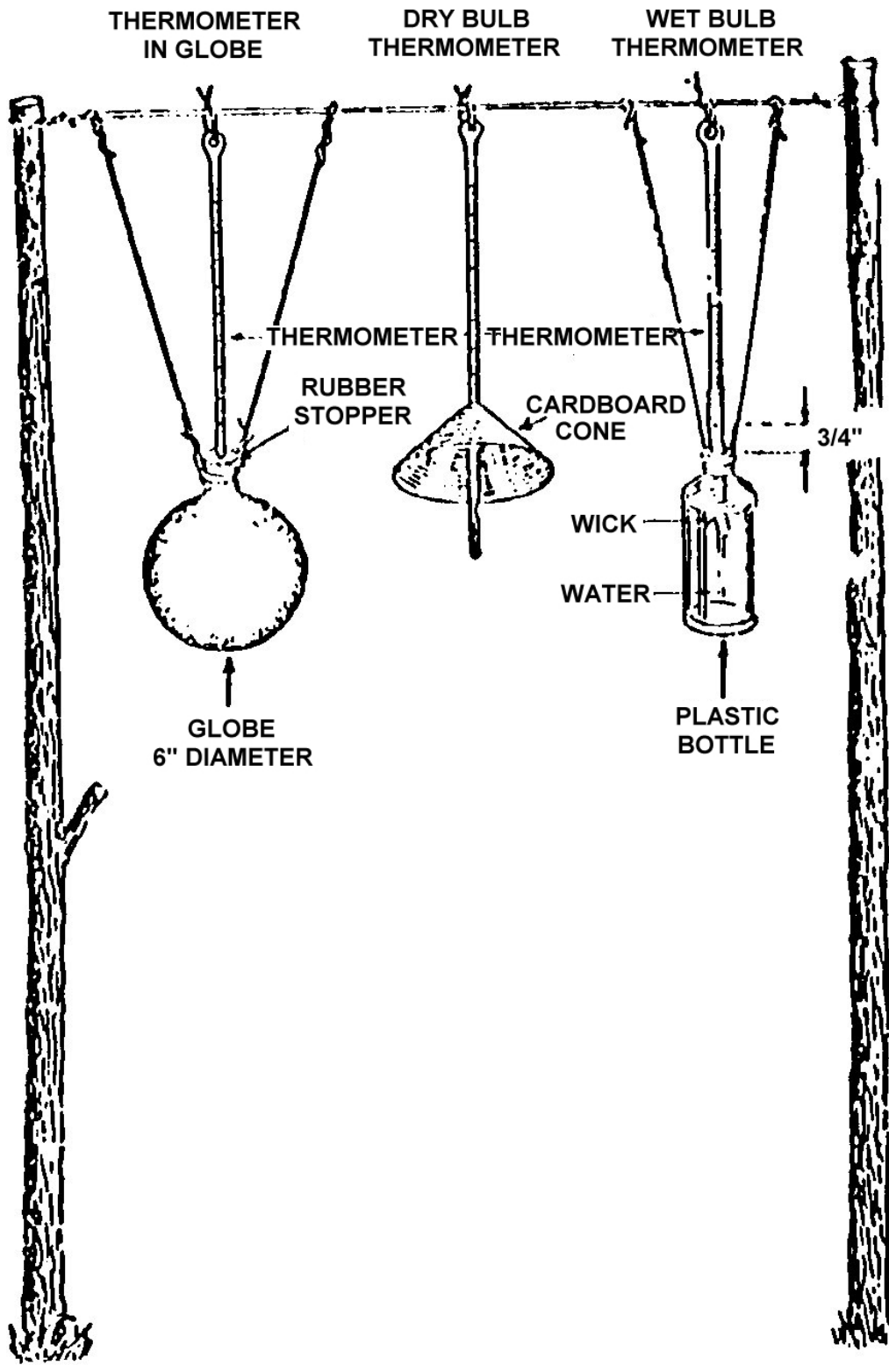

Figure 4-1. WBGT index--field apparatus.



#### **4-23. USE OF THE WET BULB GLOBE TEMPERATURE INDEX INDEX**

The proponents of the WBGT index have proposed the following as a standard for application of the index.

- a. When the WBGT index exceeds 82°, discretion should be used in planning heavy exercise for unseasoned personnel.
- b. When the WBGT index reaches 85°, strenuous exercises, such as marching at standard cadence, should be suspended for unseasoned personnel during their first 2 weeks of training. At this temperature, training activities may be continued on a reduced scale after the second week of training.
- c. Outdoor classes in the sun should be avoided when the WBGT index exceeds 85°.
- d. Strenuous exercise should be curtailed for all recruits and other trainees with less than 12-weeks training in hot weather when the WBGT index reaches 88°. Seasoned personnel, after having been acclimatized each season can carry on limited activity at WBGT indexes of 88° to 90° for periods not exceeding 6 hours a day.

#### **4-24. EDUCATION**

As noted in paragraph 4-14, prevention of heat casualties depends largely on the education of personnel exposed and especially upon supervision by informed responsible commanders. Every individual exposed to unaccustomed high temperatures should be informed of the potentially serious results of heat injury, the general nature of these conditions, and how they can be prevented. Supervisors and responsible officers must, in addition, be able to identify environmental conditions under which adverse effects of heat are likely to occur. They should recognize the earliest signs of heat injury and take appropriate action to prevent the development of cases. All personnel should be able to apply effective first aid. Mental confusion and overactivity may precede collapse from heatstroke. Supervisors must be alert to detect this condition, enforce rest, and obtain medical assistance promptly. Responsible medical officers should assist commanders in the development of local programs for heat injury prevention and continuously observe and advise in its applications.

**Continue with Exercises**

## EXERCISES, LESSON 4

**INSTRUCTIONS.** The following exercises are to be answered by marking the lettered response that best answers the question or best completes the incomplete statement or by writing the answer in the space provided.

After you have completed all the exercises, turn to "Solution to Exercises" at the end of the lesson and check your answers.

1. Which of the following may result from temperatures below freezing?
  - a. Trench foot.
  - b. Immersion foot.
  - c. Frostbite.
  - d. Chilblains.
  
2. Which of the following is a sign of injury from cold?
  - a. Stiff joints.
  - b. A hard, white, cold, and insensitive extremity.
  - c. A red nose.
  - d. Blue ears.
  
3. Which of the following, if any, is not of significant military importance?
  - a. Immersion foot.
  - b. Trench foot.
  - c. Chilblains.
  - d. None of the above.

4. All of the following, EXCEPT that in choice \_\_\_below account for the fact that there is a decreased incidence of cold injury among personnel of higher rank.
  - a. Possible lesser degree of exposure.
  - b. Prior experience.
  - c. Receptivity to training.
  - d. Type of uniform worn.
  
5. What effect, if any, does a decrease in physical activity have on exposure time necessary to produce cold injury?
  - a. Decreases the exposure time.
  - b. Increases the exposure time.
  - c. Has no effect on time.
  
6. If the ambient temperature is 40°F and the wind velocity is 20 miles per hour, the effect of the wind upon exposed skin is equivalent to a temperature of \_\_\_\_\_°F under calm conditions.
  
7. Prevention of cold injury in the Army is the responsibility of:
  - a. Cold injury officers.
  - b. The Army Medical Department.
  - c. Clothing research firms.
  - d. Command.

8. By what method does the body lose heat when the temperature of the surrounding, stationary air is below the body temperature?
  - a. Conduction.
  - b. Indirection.
  - c. Radiation.
  - d. Vaporization.
  
9. In what way should the cold weather uniform fit military personnel?
  - a. Tightly.
  - b. Snugly.
  - c. Loosely.
  - d. "Form fitting."
  
10. The most important phase of treatment for a heatstroke casualty is the:
  - a. Administration of oxygen.
  - b. Administration of physiological saline solution.
  - c. Use of sedative drugs to improve the heat regulating center.
  - d. Cool the patient.
  
11. During which of the following listed types of cold weather duty is cold most likely to occur?
  - a. Static defense or holding action.
  - b. Active offense or defense.
  - c. Reserve unit in support of attacking units.
  - d. Reserve unit in support of units fighting a delaying action.

12. You are monitoring a rising WBGT Index. You should plan to suspend unshaded outdoor classes when the index passes:
- a. 75.
  - b. 80.
  - c. 85.
  - d. 90.
13. Treatment of victims of heat cramps mainly involves:
- a. Replacing lost fluid.
  - b. Replacing lost salt.
  - c. Giving antiemetics.
  - d. Lowering the body temperature.
14. The danger sign most indicative of impending heatstroke during hard labor in a hot climate is:
- a. Profuse sweating.
  - b. Stoppage of sweating.
  - c. Muscular pains.
  - d. Pale, damp skin.
15. Salt routinely lost from profuse sweating should be replaced:
- a. By consuming 1 or 2 salt tablets.
  - b. Only by normal salting of food.
  - c. With IV solutions.
  - d. With a 0.1% saline oral solution.

16. If the shaded dry bulb temperature is 85°F, the wet bulb temperature is 80°F, and the black globe temperature is 90°F, what is the WBGT Index?
- a. 82.5.
  - b. 84.5.
  - c. 85.5.
  - d. 87.5.
17. Which of the following choices describes the condition of a victim of heat exhaustion?
- a. Severe cramps in the muscles of the lower extremities and abdominal wall.
  - b. Mental confusion, drowsiness, vomiting, visual disturbances, and profuse sweating.
  - c. High body temperature, profound coma, convulsions, and absence of sweating.
18. The point to which the rectal temperature of a heatstroke patient should be lowered as quickly as possible is \_\_\_\_\_ degrees Fahrenheit.
- a. 102.
  - b. 100.
  - c. 98.6.
  - d. 96.8.

19. Your health interest under heat stress conditions will be best served if you restrict your water consumption to:
- a. Small amounts at frequent intervals.
  - b. Large quantities just before meals.
  - c. Large quantities in the early morning and the late evening.
  - d. Small amount during meals.
20. A group of 12 men will make a one-day march in 82°F temperature (WGBT index figure). How many gallons of drinking water should they plan to have available for the march?
- a. 21.
  - b. 33.
  - c. 84.
  - d. 132.
21. When case fatality rates for heatstroke, heat exhaustion, and heat cramps are compared, which, if any, is markedly the highest?
- a. Heat exhaustion.
  - b. Heatstroke.
  - c. Heat cramps.
  - d. None; they are about equal.

22. Given the air temperatures of 10°F with 20 mph wind, the effective wind chill will be:
- a. 4°F.
  - b. 25°F.
  - c. -53°F.
  - d. -46°F.
23. Personnel who are unseasoned to heat should be acclimatized with progressive degrees of heat exposure and physical exertion. This period of acclimatization should be about \_\_\_\_\_ weeks.
- a. 2.
  - b. 3.
  - c. 4.
  - d. 5.

**Check Your Answers on Next Page**



## SOLUTIONS TO EXERCISES, LESSON 4

1. c (para 4-1c)
2. b (para 4-5a)
3. c (paras 4-1a, b)
4. d (para 4-3)
5. a (para 4-4c)
6. 18 (table 4-1)
7. d (para 4-6a)
8. a (para 4-2d)
9. c (para 4- )
10. d (para 4-13b)
11. b (para 4-2c)
12. c (para 4-23c)
13. b. (para 4-11b)
14. b (para 4-13)
15. b (para 4-16)

16. a (para 4-22d

$$\begin{aligned}0.7 \times 80 &= 56 \\0.2 \times 90 &= 18 \\0.1 \times 85 &= \underline{8.5} \\ \text{WBGT} &= 82.5\end{aligned}$$

17. b (para 4-12)
18. b (para 4-13)
19. a (para 4-15a)
20. b (table 4-3)

$$\frac{12 \times 11 \text{ qt/day}}{4 \text{ qt/gal}} = 33 \text{ gal}$$

- 21. b (para 4-13)
- 22. b (table 4-1)
- 23. a (para 4-17a)

**End of Lesson 4**

## **LESSON ASSIGNMENT**

### **LESSON 5**

Medical Aspects of Water Supply.

### **LESSON ASSIGNMENT**

Paragraphs 5-1 through 5-15.

### **LESSON OBJECTIVES**

After completing this lesson, you should be able to:

- 5-1. Identify the individuals having major water supply responsibilities and identify those responsibilities.
- 5-2. Apply appropriate terminology used in water treatment.
- 5-3. Associate the various steps in the water treatment process with the quality improvements they are designed to achieve.

### **SUGGESTION**

After completing the assignment, complete the exercises at the end of this lesson. These exercises will help you to achieve the lesson objectives.

## LESSON 5

### MEDICAL ASPECTS OF WATER SUPPLY

#### Section I. INTRODUCTION

##### 5-1. GENERAL

a. People--like all other living things--cannot live without water. An adequate supply of water is essential to the success of any military operation. During times of extreme heat, lack of water can put a soldier out of action within a day. However, an adequate supply of water in itself is not sufficient to sustain a military force. The water must be safe for human consumption; otherwise, the results may be disastrous. We who are raised in the relatively sanitary environment of the US tend to take our water supplies and their potability for granted. However, when we find ourselves in a field environment--particularly overseas--this attitude of complacency must change. All water must be considered suspect until proven safe.

b. American cities, as well as US military installations, rarely experience any problems with water potability. Water supplies come from approved sources, are treated according to public health standards, and are closely monitored. A public utility company normally operates the city water distribution system under the supervision of technically qualified engineers and sanitarians. On a military installation, the Director of Facilities and Engineering (DFAE) and his staff perform the same function. Under field conditions, however, a situation is much different. The best water source may be of questionable quality. Although the water may be properly treated, it is often necessary to transfer it from one container to another several times before it is consumed, thereby introducing the possibility of recontamination. The Quarter Master Corps and the AMEDD can no longer exercise the same degree of control as in garrison. Accordingly, water becomes everyone's problem.

##### 5-2. RESPONSIBILITIES

a. **Commander.** Basically, as in all other military matters, the commander is responsible for ensuring that his troops have an adequate supply of safe water at all times. In practice, the commander delegates the tasks of water procurement, treatment, storage, surveillance, transportation, and distribution to his staff officers; however, he always retains the ultimate responsibility for the performance of these tasks. In addition, he is responsible for enforcing, through the chain of command, strict water discipline. Water discipline is based on the following rules:

(1) Drink water only if it is from an approved source or has been purified according to accepted procedures.

- (2) Do not waste purified water.
- (3) Do not contaminate or pollute water sources.

b. **Corps of Engineers.** The Corps of Engineers, under the supervision and direction of the command or installation engineer (DFAE), is responsible for locating and developing water sources. In fixed installations, this responsibility includes pumping from the source, treatment, storage, and distribution through the plumbing systems of buildings.

c. **Quartermaster.** The Quartermaster is tasked with treating the water as necessary to render it potable, storing it in sanitary facilities, and distributing it to the consumers. In the field, distribution normally terminates with the establishment of water points, where the water is stored for consumers to pick up in their own vehicles and containers.

d. **Army Medical Department.** The AMEDD personnel, under the supervision and direction of the command or installation director of health services (DHS), are responsible for the surveillance of water supply operations to ensure that all water supplies are safe. Surveillance includes the inspection of water sources, water points, and facilities in addition to the conduct of bacteriological, chemical, and radiological tests of treated water. The DHS also makes recommendations and offers advice to both the commander and the engineer/quarter master on all health aspects of water supply.

e. **Individual Units.** Logistics elements of major units allocate resources, establish distribution schedules and control at water points, and procure additional resources (vehicles, containers, and labor) for their subordinate units. Individual units and soldiers must know the proper procedures for individual and small-unit water purification in the event they must use water from an unapproved source (see Lesson 4).

### 5-3. DEFINITIONS

In order to properly understand the water purification process, the student should have an understanding of the terminology used in discussing water supply and treatment. The following terms will be used repeatedly throughout this lesson:

a. **Potable Water.** Potable water is water that is safe for human consumption. To be safe, it must be free of all pathogenic organisms and toxic compounds.

b. **Palatable Water.** Palatable water is water that is aesthetically pleasing to the taste; however, it may be contaminated.

c. **Contaminated Water.** Contaminated water is water that is unfit for human consumption due to the presence of pathogenic organisms or excessive levels of chemicals, organic matter, or radioactivity. Contaminated water may be palatable, but it is not potable.

d. **Polluted Water.** Polluted water is water that contains substances that make it objectionable because of appearance, taste, or odor. Polluted water is usually contaminated and may be detected easily.

e. **Brackish Water.** Brackish water is highly mineralized water that contains dissolved solids in excess of 1,000 parts per million (ppm). Brackish water is found in many regions throughout the world. Most frequently, it is found in arid or semiarid climates as ground water and as ground or surface water along seacoasts and in swampy, marshy areas where water is impounded for long periods of time.

#### 5-4. WATER REQUIREMENTS

a. **Quantity.** The quantity of water required for troops varies with the season of the year, the geographical area, and the tactical situation. In garrison, per capita consumption may be as high as 150 to 200 gallons per day. This figure, of course, includes such activities as vehicle washing, laundering clothes, watering lawns, and other uses. In the field, water usage must be restricted to essential activities--drinking, cooking, and personal hygiene. A guide for planning to meet the water requirements in a temperate zone is five gallons per man per day for drinking and cooking. When showering facilities are made available, the amount required will be at least 15 gallons per man per day. In extremely hot climates, large quantities of potable water are required to replace body fluid losses. Table 5-1 is a guide to average drinking water requirements for various activities and climatic conditions. These levels will increase when troops are performing heavy labor in temperatures of 90°F or greater with high humidity or in temperatures of 110°F or greater with low humidity. Troops should be encouraged to drink more water and to drink it more frequently than is necessary to quench sensations of thirst. The myth that men can be taught to adjust to decreased water intake has been disproved many times.

b. **Quality.** In addition to the criteria for potability (para 5-3a), there are certain characteristics that affect the quality of water. These characteristics are acquired as the water passes over and through the earth, picking up various impurities from the soil (table 5-2). The following are the most common characteristics of water:

(1) **Turbidity.** Turbidity is a muddy or unclear condition of water that is caused by suspended material. Water running over soil picks up small bits of dirt and carries them in suspension. This suspended material varies from sand, silt, and clay to organic material including decaying vegetation and animal wastes. The size of the particles carried depends on the velocity of flow. When the flow of water stops, all but the finest particles settle out. Ground water (para 1-5) is clearer than surface water because of the natural filtration process it undergoes in percolating through the soil.

| ACTIVITY   | ILLUSTRATIVE DUTIES  | QUARTS OF WATER PER MAN PER DAY |                     |
|--|--|---------------------------------|---------------------|
|  |  | Moderate Conditions*            | Severe Conditions** |
| Light  | Desk   | 6                               | 10                  |
| Moderate   | Route march  | 7                               | 11                  |
| Heavy  | Forced marches, stevedoring, entrenching, or route marches with heavy loads or in CBR protective clothing. | 9                               | 13                  |
| <p>* Moderate Conditions = below 105°F in desert and below 85°F in tropics.<br/> ** Severe Conditions = above 105°F in desert and above 85°F in tropics.</p> |  |                                 |                     |

Table 5-1. Guide to average drinking water requirements.

(2) Color. The true color of water is usually caused by organic substances such as decaying vegetation. For this reason, water taken from swampy sources is often highly colored. True color must be distinguished from the apparent color caused by turbidity. Color is undesirable largely because of appearance. The presence of such impurities as iron may also be detected by the color.

(3) Odor and taste. The tastes and odors found in water are caused by algae (minute water plants), decomposing organic matter, dissolved gases, industrial wastes, or certain mineral substances. The presence of bone oil and fish oil is especially undesirable. Tastes and odors are more prevalent in surface water than in ground water; cold water has less taste and odor than warm water. The odors are usually described as aromatic, disagreeable, fishy, moldy, sweetish, and vegetable. The strength of the odor varies from very faint to very strong.

(4) pH value. Impurities in water fall into two general groups, acidic (vinegary) and alkaline (like lye). As water may contain both acidic and alkaline materials, it is necessary to know the quantity of each because these impurities may seriously affect such purification processes as coagulation and sedimentation and may cause corrosive action. The pH value is a measure of the strength of acidity or alkalinity expressed as a number ranging from zero for maximum acidity to 14 for maximum alkalinity. It is measured on a scale (figure 5-1) with 14 divisions. A pH value of seven indicates a neutral water, which means that whatever acid and alkaline substances are dissolved in water are equal in strength. If acid substances predominate, the pH value would be less than seven. A pH greater than seven indicates that the water is alkaline. Neutral water is seldom found in nature and is not necessary. A pH value of seven is not an indication that the water is pure. The pH value may be determined by a color comparator (figure 5-1).

|   |                       |                       |                                      |  |
|---|-----------------------|-----------------------|--------------------------------------|--|
| <b>SUSPENDED IMPURITIES</b>   | Microscopic organisms |                       | Some cause disease                   |  |
|   | Algae                 |                       | Causes taste, odor, color, turbidity |  |
|   | Suspended solids      |                       | Causes murkiness or turbidity        |  |
| <b>DISSOLVED IMPURITIES</b>   | SALTS                 | CALCIUM AND MAGNESIUM | Bicarbonate                          | Causes alkalinity, hardness                            |
|   |                       |                       | Carbonate                            | Causes alkalinity, hardness                            |
|   |                       |                       | Sulfate                              | Causes hardness  |
|   |                       |                       | Chloride                             | Causes hardness corrosive to boilers                   |
|   |                       | SODIUM                | Bicarbonate                          | Causes alkalinity                                      |
|   |                       |                       | Carbonate                            | Causes alkalinity                                      |
|   |                       |                       | Sulfate                              | Causes foaming in steam boilers                        |
|   |                       |                       | Fluoride                             | Causes mottled enamel of developing teeth in children* |
|   | Chloride              | Causes salty taste    |                                      |  |
|   | IRON                  |                       |                                      | Causes taste, red water, incrustations on metals       |
|   | MANGANESE             |                       |                                      | Causes black or brown water                            |
|   | VEGETABLE DYE         |                       |                                      | Causes color, acidity                                  |
|   | GASES                 |                       | Oxygen                               | Causes corrosion to metals                             |
|   |                       |                       | Carbon dioxide                       | Causes acidity, corrosion of metals                    |
|   |                       |                       | Hydrogen sulfide                     | Causes odor, acidity, corrosion of metals              |
|   |                       |                       | Nitrogen                             | No effect  |
| * Fluoride content of water in excessive concentrations (over 1 mg/l) may cause mottled enamel of developing teeth in children. In lower concentrations, it increases resistance to dental decay. |                       |                       |                                      |  |

Table 5-2. Common impurities in water.



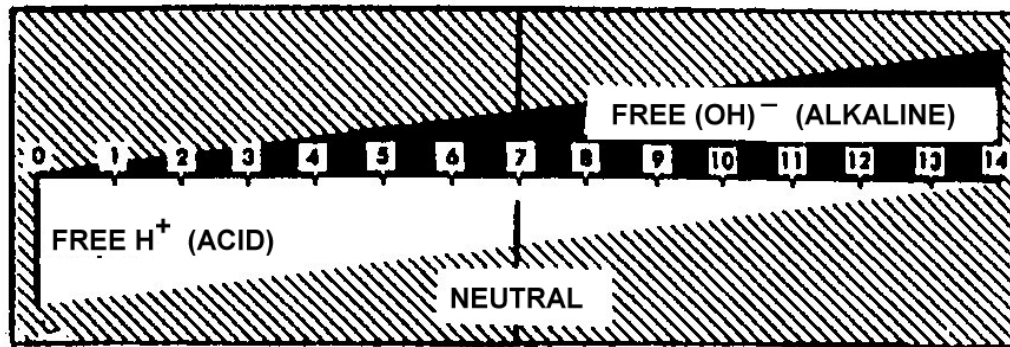

Figure 5-1. The pH scale.

**NOTE:** A few substances have the capability to absorb any tendency of the water to become acid or alkaline. These substances can conceal acid or alkaline impurities. Therefore, if a pH test is made and if that test shows the water to be neutral, there is no guarantee that the acid or alkaline impurities are completely absent.

(5) Hardness. Hardness is caused by soluble salts in water (table 5-2). The degree of hardness depends on the type and on the amount of impurities present in the water. Hardness is undesirable in that it consumes soap, makes water less satisfactory for cooking, and produces scale in boilers and distillation units.

(6) Dissolved gases.

(a) Oxygen. Large amounts of dissolved oxygen are found in rainwater. The amounts in surface water vary. The oxygen, especially when carbon dioxide is also present, causes many metals to corrode. Presence of game fish in surface water is a good indication of high dissolved oxygen content.

(b) Carbon dioxide. Carbon dioxide enters the water from the atmosphere, from decomposing vegetation, and from underground sources. It then forms carbonic acid, which aids in the formation of bicarbonates of calcium and magnesium.

(c) Hydrogen sulfide. Hydrogen sulfide gives water a rotten-egg odor. It is also corrosive to metals. In small amounts, it is unpleasant; in large amounts, hydrogen sulfide is also harmful. It is produced by decomposition of organic matter and by breakdown of certain compounds containing sulphur. Water having a rotten-egg odor quite likely contains sewage or large amount of animal or industrial wastes.

## 5-5. SOURCES OF WATER

The staff engineer is responsible for locating and developing water sources. The senior medical advisor, in cooperation with the engineer, gives advice and makes recommendations on the selection of water sources. In the selection of a water source, many factors are considered--the tactical situation, the quantity of water needed, the quality of the source, the accessibility of the source, and the type of purification equipment available. The possible sources of water are a public water supply system (the preferred source), surface water, ground water, rain collected from roofs or other catchment surfaces, ice or snow, and distilled seawater. Water taken from any of these sources, except a public water supply system approved by the AMEDD, must be properly treated before use, as all of them are presumed to be contaminated.

a. **Surface Water.** Surface water sources include lakes, rivers, streams, and ponds. These sources are ordinarily more contaminated than ground sources, but they are frequently selected because of their greater quantity and accessibility. Virtually all surface waters are contaminated to some extent with fecal materials; therefore, all such water is considered unfit for human consumption until it is adequately treated.

b. **Ground Water.** Ground water--that obtained from wells and springs---is usually less contaminated than surface water. It is therefore a more desirable source. However, the limited supply provided by a well or spring may render it impractical as a source of water for large units. Because of the time and labor involved in digging or drilling wells, combat units normally select this source only when existing wells or springs are available. Although well or spring water may be aesthetically pleasing in appearance and odor, it must be presumed to be contaminated and therefore must be treated before use.

c. **Other Water Sources.** Rain, melted snow or ice, or sea water may be used in special instances where neither surface nor ground water is available. Water obtained from any of these sources must be treated before use. Sea water cannot be used for human consumption until the salt has been removed by distillation.

## Section II. PRINCIPLES OF WATER PURIFICATION

### 5-6. GENERAL

Purification is the process of removing or destroying enough of the impurities present in water to make the water safe and pleasant to drink. The amount and type of treatment required depends on the quality of the raw water, the quantity of purified water needed, and the degree of purification required. A series of treatment processes is generally employed. A good quality water ordinarily results after treatment of raw water with the following arrangement of processes--coagulation, sedimentation, filtration, and disinfection. Under certain conditions, additional treatment processes are required to remove undesirable dissolved impurities.

## 5-7. SEDIMENTATION

The process of allowing suspended solids to settle out of the water without the addition of chemical coagulants is called plain sedimentation. The turbidity of water from swiftly flowing, silt laden streams can be reduced considerably by holding the water in plain sedimentation tanks or basins. The rate of settling of the particles being removed varies with their diameter and specific gravity. The larger particles settle out quickly in still water, but small particles such as silt may require a period of days to settle out. For complete treatment, the retention periods would be excessive. Therefore, plain sedimentation is not ordinarily used by the Army as a separate step in water purification.

## 5-8. COAGULATION

a. **Pretreatment.** Certain chemicals, when added to water, cause the small suspended particles to coagulate into larger ones which, because of their weight, settle out more quickly. The partial clarification of water by coagulation prior to filtration is known as pretreatment. Proper pretreatment reduces the amount of suspended matter in water and is especially important for very turbid sources. Pretreatment prevents rapid clogging of filters and ensures a filtered water with a uniformly low turbidity.

b. **Flocculation.** The coagulant can be added to water in tanks, such as the standard 3,000-gallon tank, or it may be added continuously to water by mechanical feeding devices. In either case, the water must be stirred after the chemicals have been added. Initially, a "jellylike" substance appears in the form of small particles that give the water a milky appearance. These small particles will not settle out. It is necessary to continue stirring the water until the small particles unite to form larger particles that will settle rapidly. The formation of the large jellylike particles, or "floc," through agitation is called flocculation. A heavy, rapid-settling floc is desirable for efficient treatment.

c. **Optimum pH.** The optimum pH value of water is that value at which the floc is heaviest and forms fastest. This value, which is dependent on the water characteristics, can be determined by the jar test. In this test, varying amounts of coagulant and alkali are added to water in six jars. The samples are stirred and the appearance of the floc, its settle ability, and the pH value of the water are noted. Because the water quality fluctuates considerably, the pH value should be checked frequently.

d. **Color Removal.** Vegetable dyes from decomposing vegetation cause colors in water that can be removed by careful control of pH in the acid range in the coagulation process. Activated carbon will also absorb and remove most true color from water.

## 5-9. DIATOMITE FILTRATION

The process of removing suspended matter from water by passing the water through a layer of diatomaceous silica is known as diatomite filtration. The effluent obtained by diatomite filtration of pretreated water has a very low turbidity and is free of amoebic cysts and cercariae of schistosomes. Over 90 percent of all bacteria are removed by diatomite filtration without chlorination. Even better results may be obtained with careful operation and decreased rate of flow.

## 5-10. DISINFECTION

a. **General.** Water must be disinfected after undergoing treatment, because no purification process or combination of processes will reliably remove all disease-producing organisms from water. There is also danger of contamination during rehandling and transportation before consumption. Disinfection, the process of destroying disease agents, may be accomplished by adding chemicals such as chlorine gas, chlorine solutions, iodine, or by boiling. Freezing does not disinfect water or make the ice safe. Addition of coffee, tea, or beverage powders does not make water potable. Chlorination is the most commonly used method of disinfection.

### b. Chlorination.

(1) Chlorine added to water becomes bound in chemical reactions with chlorine-consuming substances (chlorine "demand") in the water. In the process, pathogens are killed. The chlorination method of disinfection involves putting in enough chlorine to satisfy this chlorine demand plus a small amount in excess. The excess assures a proper kill of pathogens in the water and acts on contaminants that may enter the water later. The ratio of chlorine to water is expressed as parts per million (ppm)--number of units of chlorine in one million parts of water by weight--or as milligrams per liter (mg/l)--(since a liter of water weighs one million milligrams).

(a) Chlorine dosage is the amount of chlorine added to a given quantity of water. This amount should be sufficient to satisfy the chlorine demand as well as to provide a residual after a specified time.

(b) Chlorine residual, or residual chlorine, is the chlorine that remains in the water after the demand of all chlorine-consuming agents has been satisfied. A chlorine residual of five parts per million at the point of water consumption is the standard requirement in waters treated under field conditions, especially overseas. Based upon a specific situation, the staff surgeon may dictate a higher residual. Only a part of the total chlorine residual in water is in a form that will act effectively as a

disinfectant. This part of the residual is termed free available chlorine. Unless otherwise stated, all chlorine residual values given in this text are in terms of free available chlorine. Chlorine residuals required at water points or other spots where chlorine is added to water are discussed with treatment processes described in subsequent paragraphs. Chlorine residual equals the chlorine dosage minus the chlorine demand.

(c) Chlorine demand is the amount of chlorine dosage that reacts with and is consumed by organic material, bacteria, and other material in the water. Chlorine demand varies with the nature and quantity of chlorine-consuming agents, the pH value and temperature of the water, and the contact period. Some disease organisms will be destroyed by the time chlorine demand is satisfied, but a moderately stable chlorine residual should be permitted to act for an additional length of time to effect satisfactory destruction of resistant organisms such as the virus of hepatitis, the cysts of Entamoeba histolytic (the causative agent for amoebic dysentery or amebiasis), and the larvae of schistosomes. Chlorine demand equals the difference between the chlorine dosage and the chlorine residual.

(d) Disinfecting time is the time required for chlorine in a water to effect satisfactory disinfection. Chlorine demand in most waters is virtually satisfied 10 minutes after the chlorine is added. When a satisfactory chlorine residual remains after the 10-minute contact period, satisfactory disinfecting action usually results after an additional 20 minutes of contact between water and chlorine. It is for this reason that, for field chlorination, water having a satisfactory chlorine residual after 10 minutes is allowed to stand an additional 20 minutes before being consumed.

(2) Calcium hypochlorite  $\text{Ca}(\text{ClO})_2$  is the chemical most commonly used for disinfection of water in the field. When calcium hypochlorite powder is dissolved in water, it reacts with the water to form a disinfectant (hypochlorous acid,  $\text{HClO}$ ) plus other products. Only 70 percent of the  $\text{Ca}(\text{ClO})_2$  is available for the formation of  $\text{HClO}$ ; therefore, when calcium hypochlorite is used in bulk, chlorine dosage imparted to a water is computed on the basis of this available part, which is referred to as available chlorine. For example, 1,000 grams of  $\text{Ca}(\text{ClO})_2$  supplies a chlorine dosage of 700 grams.

### **Section III. QUARTERMASTER WATER TREATMENT**

#### **5-11. CONTINUOUS FLOW TYPE WATER PURIFICATION EQUIPMENT**

Quartermaster water purification equipment (figure 5-2) is designed for continuous purification of natural raw water by the solids contact method of water treatment. Suspended solids contact units, sometimes called upward flow units, combine mixing, flocculation, and clarification in the same structure.

a. **Principles of Operation.** Raw water enters at the top through aspirator type orifices, which provide aeration of the influent to reduce tastes and odors caused by organic decomposition, to remove hydrogen sulfide, and to reduce certain chemical agents of war. The water overflows from the pre-aeration tank into the mixing compartment, where it is thoroughly mixed with ferric chloride, pulverized limestone, calcium hypochlorite, and when necessary, activated carbon. These chemicals act as coagulants, remove colors and dissolved minerals, adjust pH, prechlorinate the water, and remove or reduce many poisons, including chemical agents of war. The water flows downward through the mixing zone, where it is rotated at high speed. A reverse rotation is imparted to the water when it enters the slurry energizing section. This slurry is a thin, watery paste comprised of suspended floc and other solids. Rotation of the slurry prevents a short-circuiting of the water flowing upward through it and improves flocculation. The slurry level in the clarifying chamber is maintained by a continuous withdrawal of slurry at the time of separation into a sludge concentrator that acts as a small auxiliary clarifier. The slurry can be discharged to waste from near the bottom of the sludge concentrator. The clear water is pumped to diatomite filters for further treatment.

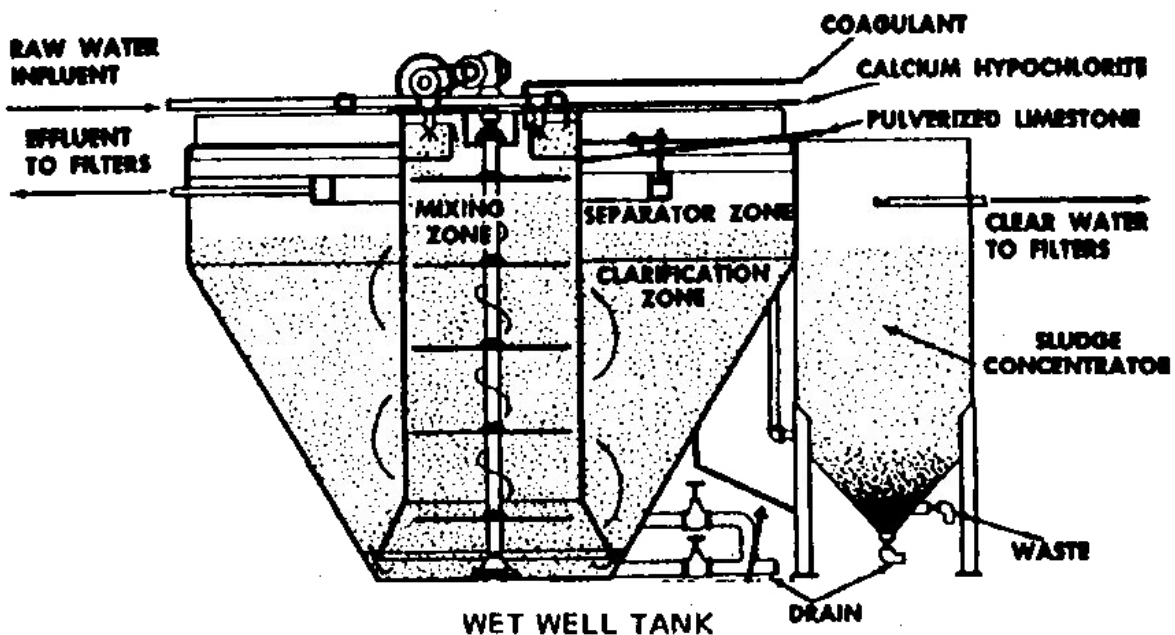

Figure 5-2. Continuous-flow coagulation assembly.

b. **Mobile Units.** Standard purification units, both mobile and base mounted, utilize the continuous flow equipment. Two mobile units, of 1,500 gallons per hour (gph) and 3,000 gph output, are truck mounted (figure 5-3). A raw water pump, chemical feeders, filter pump, either one or two diatomite filters, and an electrical control panel are located in the truck body with the coagulator assembly. A gasoline engine driven generator, trailer mounted, provides the required electric power for the pumps, chemical feeders, and all other powered components, including the illumination needed for night operation. Figure 5-4 shows a typical layout for the mobile unit. A scaled down model of the mobile unit is trailer mounted and has a capacity of 600 gph. It is powered by a

portable engine driven generator set. These portable purification units are known as erdlators (from the developing agency, Engineering Research and Development Laboratory). From the erdlator, treated water is pumped to rubberized fabric tanks (figure 5-5) for storage.

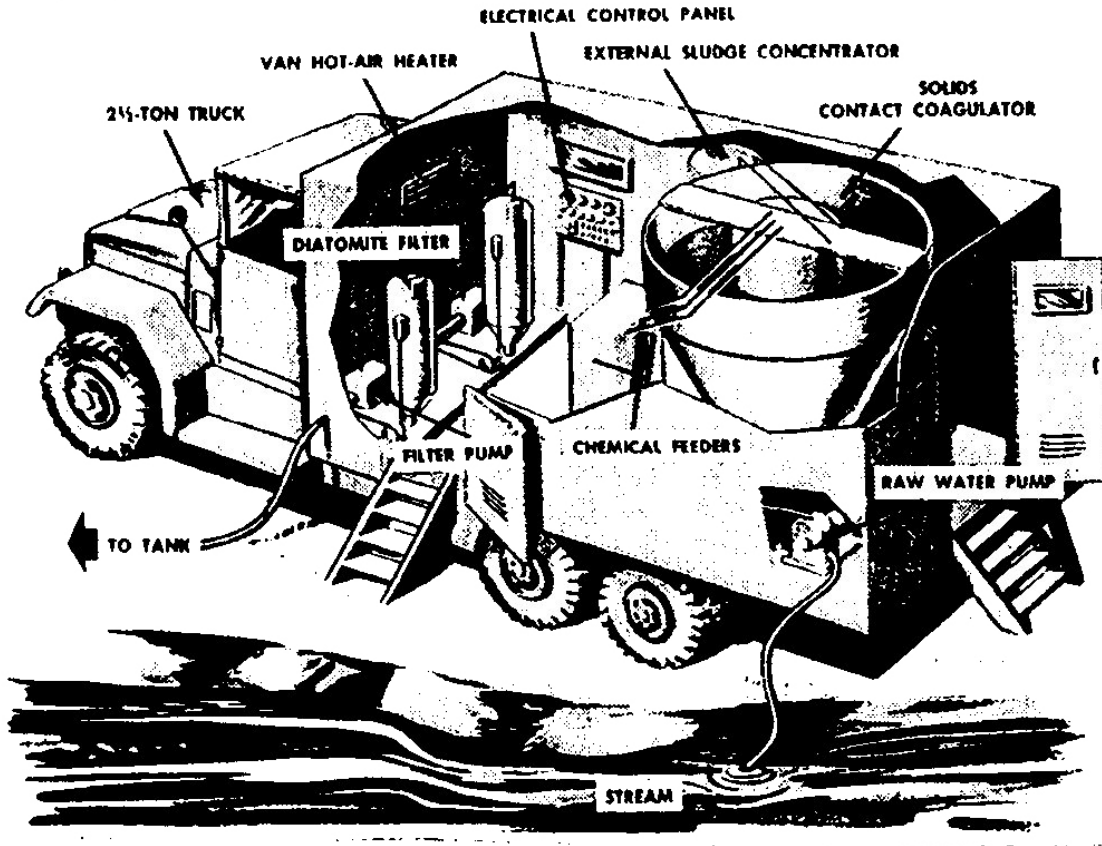

Figure 5-3. Water purification unit, van type body mounted. This entire device is commonly known as an erdlator

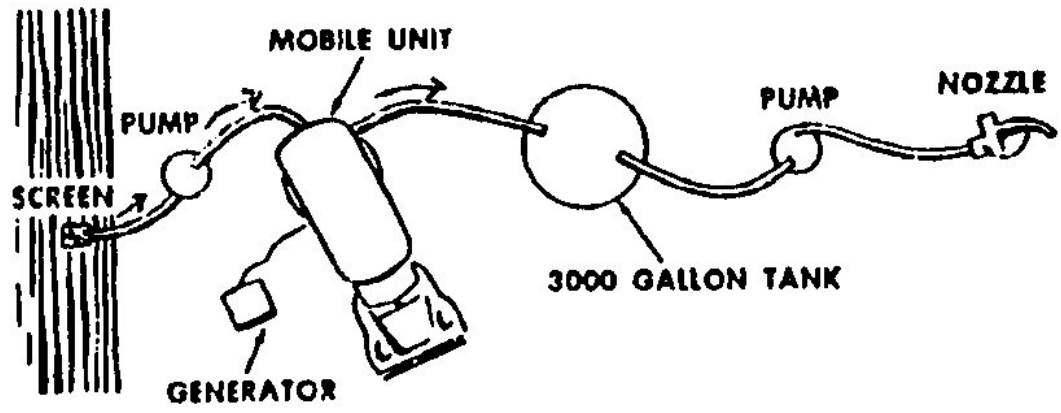

Figure 5-4. Typical layout for mobile purification units.

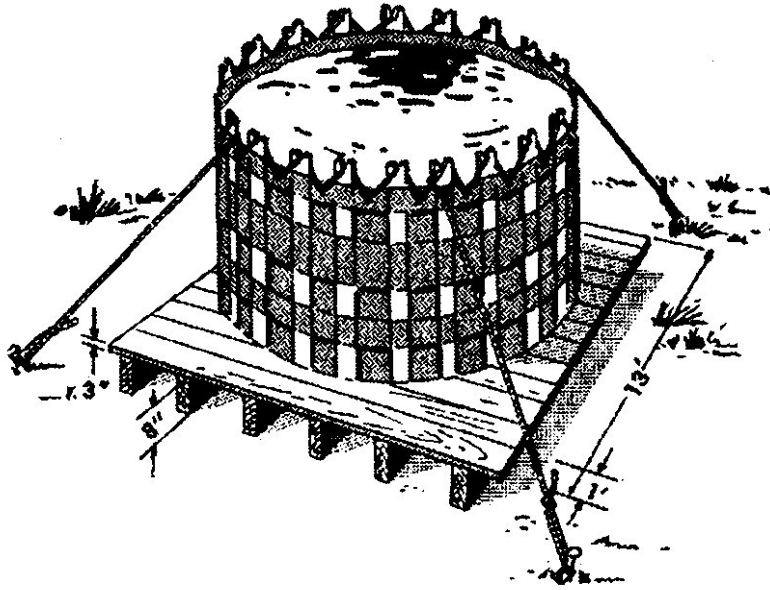

Figure 5-5. 3,000-gallon fabric tank erected on ground platform made of dimensioned lumber.

## 5-12. DIATOMITE FILTERS

Diatomite filters are included in several sets of Army equipment containing pumps, tanks, and supplies that provide for pretreatment, chlorination, filtering, water storage, and distribution. The diatomite filter unit is the most effective filtration system ever devised by the Army and one of the most effective in existence. Diatomite, also known as diatomaceous earth or filteraid, consists of the skeletal remains of minute algae, called diatoms, found in marine deposits that have been lifted above sea level. It is quarried and processed as filteraid, which is inert to water and water-treatment chemicals.

## 5-13. CHLORINATION

Diatomite filtration of pretreated water removes over 90 percent of the bacteria, all of the amoebic cysts, and all of the schistosome cercariae that may be present in the water. However, the virus of infectious hepatitis is not removed or inactivated by this treatment. Accordingly, the effluent from diatomite filters must be chlorinated to have a minimum residual of 5 ppm after a 10-minute contact period. When the water temperature is near freezing and the pH is near 7.0, a residual of not less than 10 ppm is required. Chlorinated water must be allowed to stand an additional 20 minutes before consumption. Higher residuals may be required when low temperature and high pH conditions coexist in a water or when chlorine-demanding agents in the water distribution system, introduced by subsequent rehandling, cause the residual to fall below the standard chlorine residual (usually 5 ppm) after a 30-minute waiting period subsequent to chlorination.



## 5-14. DETERMINING CHLORINE RESIDUAL AND pH

The chlorine residual in water is measured with a comparator test kit (figure 5-6). The comparator is a viewing device in which the color developed in a treated water sample is compared with standard colors mounted on discs that can be inserted and rotated in the comparator. The comparator has a dual use. Procedures and reagents can be varied so that either the chlorine residual or the pH of a water sample can be read directly from the colored disc matched by the water sample. The pH is important in that the amount of free available chlorine required to kill the organisms in a given water sample varies directly with the pH. For example, water with a pH of 10 requires five times as much chlorine residual as water with a pH of seven. The water quality control set, of which the color comparator is a component part, contains detailed instructions for determining both the free available chlorine residual and the pH of a water sample. Sets are found in engineer units, preventive medicine units, and Army medical laboratories.

## 5-15. OTHER QUALITY TESTS

In addition to the determination of chlorine residual and pH, Corps of Engineers personnel also conduct tests for turbidity, chlorine demand, salinity, alkalinity, chlorides, and sulfates.

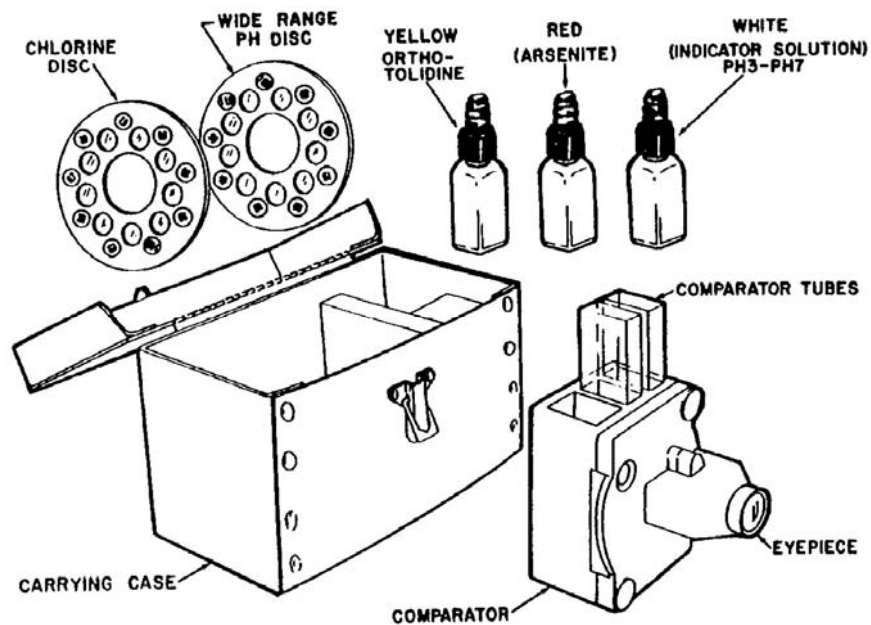

Figure 5-6. Color comparator with case.

**Continue with Exercises**

## EXERCISES, LESSON 5

**INSTRUCTIONS.** The following exercises are to be answered by marking the lettered response that best answers the question or best completes the incomplete statement or by writing the answer in the space provided.

After you have completed all the exercises, turn to "Solution to Exercises" at the end of the lesson and check your answers.

1. With regard to supplying water to troops in the field, which of the following is a medical responsibility?
  - a. Ensuring that troops will avoid drinking untreated water.
  - b. Testing water to ensure that it is safe for troop consumption.
  - c. Enforcing field sanitation measures necessary to keep troops from contaminating water sources.
  - d. Estimating the purified water requirements of troop units or commands.
  
2. Water that is safe to drink, regardless of appearance, odor, or taste, is \_\_\_\_\_.
  
3. As a general guide, a unit of 100 men in a bivouac area with improvised showers will need about \_\_\_\_\_ gallons of water per day.
  
4. In selecting a water source on its merits, first consideration should be given to:
  - a. Existing wells or springs.
  - b. Existing public or municipal sources.
  - c. Surface water sources (rivers, streams, or lakes).
  - d. New ground water sources (such as wells dug by the Corps of Engineers).

5. Water containing harmful substances, although it may be palatable, is said to be \_\_\_\_\_.
6. Approximately how much water for drinking a day is required for a detachment of four men doing heavy work in a humid climate at an average temperature of 90°F?  
\_\_\_\_\_.
7. Water that is cloudy or unclear due to suspended dirt or other matter is said to be \_\_\_\_\_.
8. Water that contains predominantly alkaline substances is said to have a high \_\_\_\_\_.
9. In Army water treatment, the steps of \_\_\_\_\_ and \_\_\_\_\_ are combined.
10. Which of the following are completely removed by a properly operated diatomite filter?
  - a. Bacteria.
  - b. Amoebic cysts.
  - c. Schistosomes.
  - d. Viruses.
11. The only step in the water purification process that will remove all pathogens is:
  - a. Sedimentation.
  - b. Flocculation.
  - c. Filtration.
  - d. Disinfection.

12. The standard requirement for chlorine residual in water treated under field conditions is \_\_\_\_\_ parts per million (ppm).
13. The standard time allowed for disinfection from the time chlorine is added until the time water is consumed is:
  - a. Ten minutes.
  - b. Twenty minutes.
  - c. Thirty minutes.
  - d. Forty minutes.
14. The continuous flow type water purification unit used by the Corps of Engineers is called an \_\_\_\_\_.
15. Which of the following factors increase(s) the required chlorine residual in water?
  - a. Low pH (below 5.0).
  - b. High pH (above 5.0).
  - c. Low temperature.
  - d. High temperature.
  - e. The presence of chlorine-demanding substances.
16. Quartermaster and preventive medicine units test water for chlorine residual and pH with the\_\_\_\_\_.

**Check Your Answers on Next Page**

## **SOLUTIONS TO EXERCISES, LESSON 5**

1. b (para 5-2d)
2. Potable. (para 5-3a)
3. 1,500. (para 5-4a)
4. b (para 5-5)
5. Contaminated. (para 5-3c)
6. Thirteen gallons ( $4 \times 13$  quarts = 52 quarts). (para 5-4a; Table 5-1)
7. Turbid. (para 5-4b(1))
8. pH value. (para 5-4b(4))
9. Coagulation, sedimentation. (paras 5-7, 5-8, 5-9)
10. b, c (para 5-9)
11. d (para 5-10)
12. 5 (para 5-10b)
13. c (para 5-10d)
14. Erdlator. (para 5-11b)
15. b, c, e (para 5-10b(1)(c), 5-13)
16. Color comparator. (para 5-14, figure 5-6)

**End of Lesson 5**

## **LESSON ASSIGNMENT**

### **LESSON 6**

Field Water Supply and Waste Disposal.

### **LESSON ASSIGNMENT**

Paragraphs 6-1 through 6-35.

### **LESSON OBJECTIVES**

After completing this lesson, you should be able to:

- 6-1. Select the appropriate steps to be taken in individual and unit water purification procedures for a given situation.
- 6-2. Identify proper methods of waste disposal in a field environment.

### **SUGGESTION**

After completing the assignment, complete the exercises at the end of this lesson. These exercises will help you to achieve the lesson objectives.

## LESSON 6

### FIELD WATER SUPPLY AND WASTE DISPOSAL

#### Section I. INDIVIDUAL AND UNIT WATER SUPPLY AND PURIFICATION

##### 6-1. GENERAL

a. The responsibilities for water supply were discussed in paragraph 5-2. The commander is responsible for providing his troops with water, the Quarter Master Corps and the Corps of Engineers are tasked with the actual procurement, processing, and distribution of water supplies. In a combat or field environment, Quartermaster water supply tasks terminate at the water point, where purified water is placed in containers for pickup by using units. The degree of sophistication to which a water point is developed depends upon the tactical situation, the equipment available, and the amount of time available to improve the water point. Figure 6-1 illustrates a typical combat water point.

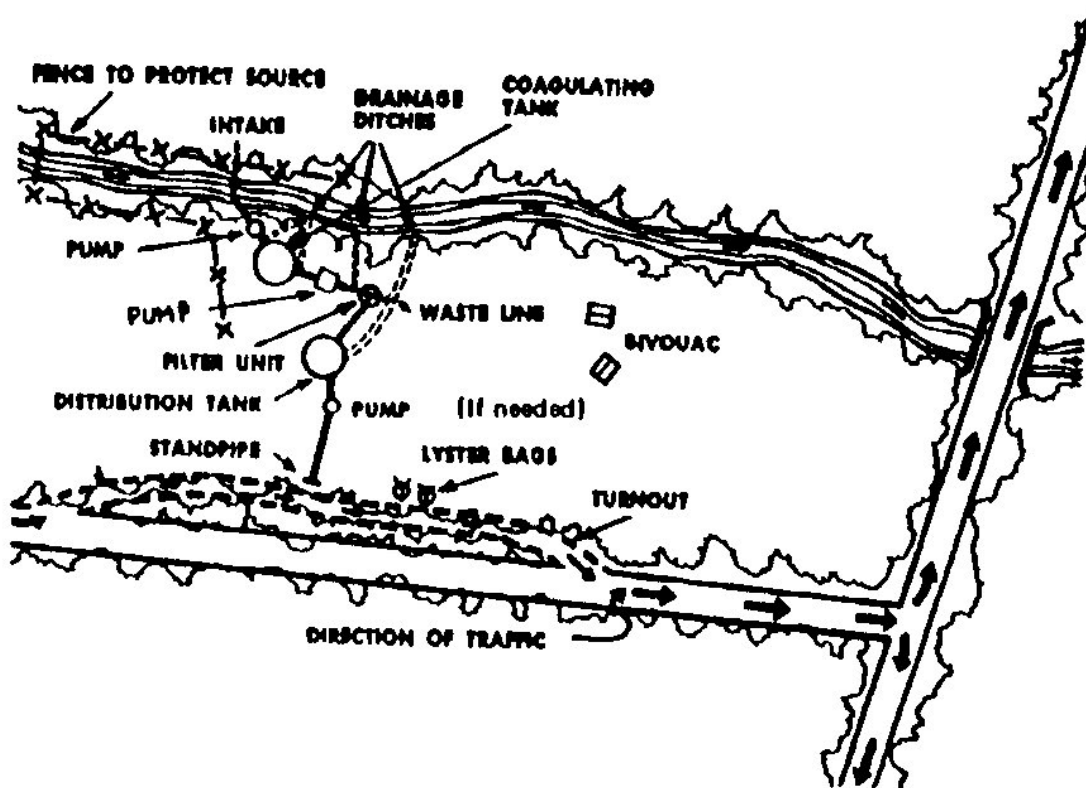

Figure 6-1. A combat water point.

b. The AMEDD personnel are responsible for monitoring water supplies to ensure that they are potable at points of distribution (para 5-2d). However, it is virtually impossible to monitor water quality to the point of consumption. Units frequently pick up water in large tank trucks and further distribute it to subordinate units by filling their water trailers. Water is then transferred from trailers to Lyster bags (figure 6-2) or 5-gallon water cans for individual and small-unit use. During the process, water is subject to further contamination through careless or improper handling and the use of contaminated containers. It is thus the unit commander's responsibility to ensure that all personnel are trained in unit and individual water purification procedures.

c. Isolated units, small patrols, and individuals may not always be able to obtain water from established water points. In such cases, they must exercise resourcefulness in exploiting the best possible water sources and follow established purification procedures to ensure the potability of the water before using it for drinking or cooking.

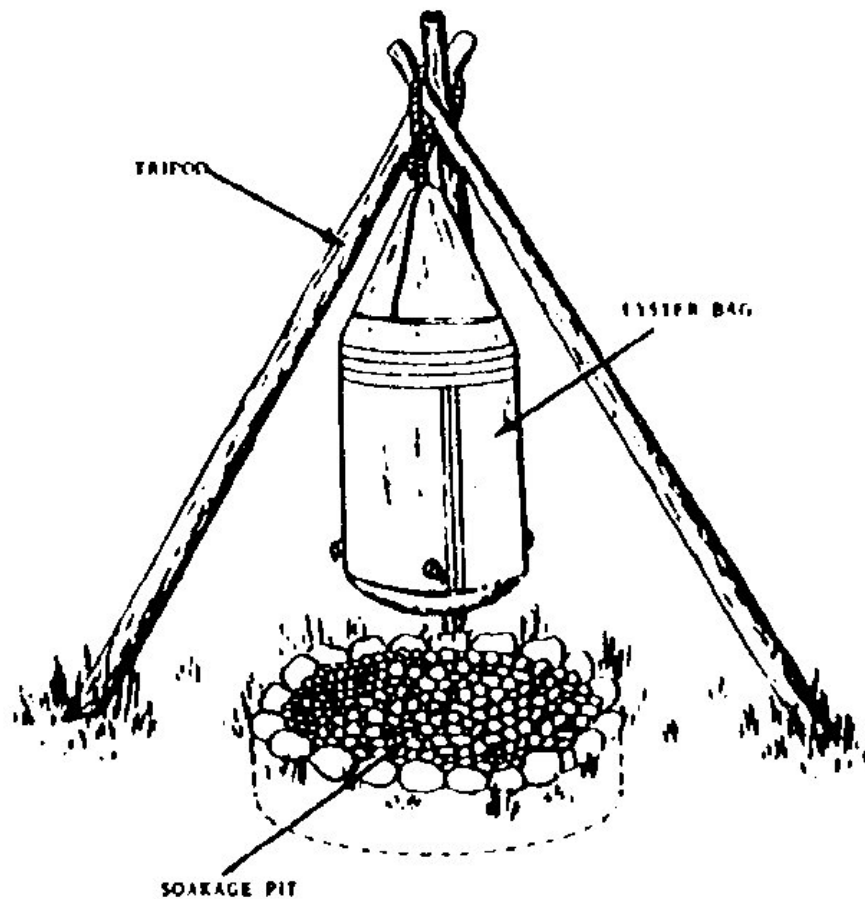

Figure 6-2. Lyster bag and soakage pit.



## 6-2. WATER RECONNAISSANCE

When an isolated unit is unable to use an established water point, the commander or a designated individual (or group of individuals) must make a search of the area for the best available source of water. The following principles should always be considered:

- a. A source should be selected which is as free as possible from known contamination.
- b. When several otherwise equally desirable sources are available, the water that is easiest to purify should be chosen. Less disinfectant is required to purify water from a clean supply than from a supply of more questionable quality.
- c. The water intake or the point of supply of a surface source should be as far away as possible from known sources of contamination. When a stream is used, the intake preferably should be upstream from any source of contamination. In lakes and ponds, it is generally desirable to locate the intake as far from the shore as practicable, since the amount of contamination usually decreases in proportion with the increase of distance from the shore.

## 6-3. UNIT WATER PURIFICATION

a. **General.** When units are not able to obtain water from established water points, they must obtain and treat their own water. When surface water is used, care should be taken to avoid getting mud from the bottom or picking up floating sticks, leaves, or other debris. Turbid or cloudy water should be settled before it is used. A settling basin may be constructed by digging a trench, parallel to the stream bank, into which the water may seep and remain still. Another method is to dig a short ditch from one side of the stream leading to a basin where the water can stand and settle. After the dirt has settled, the clear water must be disinfected. The entire reliance for rendering the water safe for consumption is placed on the disinfection process. The disinfectant most often used in purifying water for drinking and other domestic purposes is chlorine. The compound normally used to chlorinate water in the field is calcium hypochlorite.

b. **Chlorination Requirements.** Sufficient chlorine must be added to water to produce a required chlorine residual after a 30-minute contact period. Standard requirement for field water supplies is five parts per million (ppm) chlorine residual. However, higher or lower concentrations may be prescribed by the command surgeon on the basis of his knowledge of local diseases and environmental conditions. A Lyster bag or other clean container may be used to hold water for chlorination.

(1) A chlorination kit (figure 6-3) is available to all units for use in chlorinating water and testing it for the proper chlorine residual. The kit contains calcium hypochlorite ampules (0.5 gram) for disinfecting water, together with three plastic tubes and three vials of orthotolidine tablets for use in determining the chlorine residual. The vials of orthotolidine tablets are packed inside the plastic tubes. Each of the plastic tubes has a band of a different shade of yellow around it. The lightest shade of yellow indicates 1 ppm; the medium shade, five ppm; and the darkest shade, ten ppm. These figures are printed on the tubes. An orthotolidine tablet is placed in the plastic tube appropriate for the residual desired, the tablet is dissolved with water from the batch being treated with chlorine, and the resulting yellow color is compared with that of the yellow band near the top of the comparator tube. A color equal to that color on the comparator tube indicates a total chlorine residual equal to that marked on the tube.

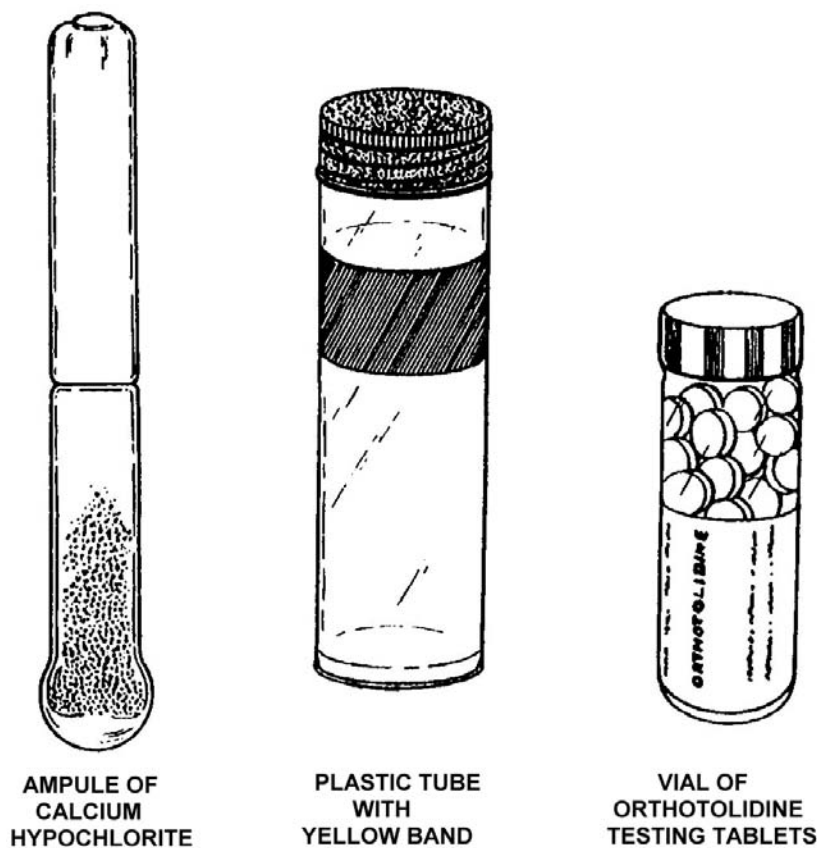

Figure 6-3. Items in chlorination kit.

**NOTE:** Total chlorine residual may or may not be the same as free available chlorine (FAC). If, however, total available chlorine residuals are obtained in the range of 5 to 10 ppm at point of treatment, it is highly likely that a significant portion of the residual will be primarily FAC.

(2) The surgeon has the responsibility for recommending total chlorine residuals that will be high enough to assure a free available chlorine residual sufficient to render water safe. For this purpose, he uses reconnaissance reports and all other data available on water sources in or near the area in which the use of emergency water treatment procedures is anticipated.

c. **Lyster Bag Chlorination Procedure.** The Lyster bag (figure 6-2) is the familiar 36-gallon canvas container issued on the basis of one bag per 100 men. The porous canvas permits cooling of the water by evaporation. Small units normally purify water in the Lyster bag. When using the Lyster bag for disinfection of raw water, proceed as follows:

(1) Clean the bag and hang it by the supporting ropes. Fill the bag to the 36-gallon mark, which is 4 inches from the top. Use clear, settled water, if possible. The supports must be sturdy, since the bag filled with water weighs almost 300 pounds.

(2) Empty the contents of at least three calcium hypochlorite ampules (figure 6-3) into a canteen cup; add a small amount of water from the Lyster bag and stir with a small stick until a thick mixture results; then fill the cup one-half full of water and stir again.

(3) Empty the prepared solution slowly into the Lyster bag, stirring the water with a clean stick. Cover the bag and clean the faucets by flushing a small quantity of the water through each of them.

(4) After the calcium hypochlorite solution has been in contact with the water for 10 minutes, flush the faucets and collect a sample of water from one of the faucets in the 5 ppm plastic tube for testing (see para (5) below). Place one orthotolidine tablet in the plastic tube and crush it with the bottom of the orthotolidine bottle. Place the cap on the tube and shake until the orthotolidine tablet is thoroughly dissolved in the water. Make the comparison.

(5) If the sample is lighter in shade than the yellow band, the chlorine residual is less than 5 ppm. Therefore, add sufficient additional ampules of calcium hypochlorite, one at a time at 10-minute intervals, to the Lyster bag. After each addition, retest after an additional 10 minutes. When the color of the water in the sample is the same shade or darker than the yellow band on the five ppm plastic tube, the chlorine residual is equal to or greater than five ppm. Wait an additional 20 minutes, since a total contact time of 30 minutes is required. Flush the faucets and check the residual again before drinking the water. If the chlorine residual is less than five ppm, repeat.

#### d. **Water Trailer Disinfection.**

(1) Significance. If the chlorine residual is inadequate for any reason, your unit has the capability to disinfect the water and make it safe to drink.

(2) Procedure. Get the jar of chlorine, a canteen cup, a spoon, and the 5 ppm test vial and you're ready to begin.

- (a) Add spoonful of calcium hypochlorite to canteen cup.
- (b) Make a slurry.
- (c) Dump the slurry into the water trailer.
- (d) Wait ten minutes.
- (e) Check to ensure more than five ppm chlorine remains. (If not, return to step 2a).
- (f) Wait for a total of 30 minutes.

e. **Boiling**. Clear water can be made safe to drink by boiling it vigorously for at least 15 seconds (at least 20 minutes if there is danger of infectious hepatitis in the area). This method usually should not be used when chemical disinfectants are available, because boiling does not protect the water from recontamination. If dirty water must be used, part of the impurities in it may settle out and may be discarded if the water is allowed to stand for a short time. In addition, part of the remaining impurities suspended in the water may be filtered out and discarded. An emergency filter may be made from a wool blanket or from local granular material (sand, pebbles).

#### 6-4. **INDIVIDUAL WATER PURIFICATION**

a. **General**. When small patrols or detachments are operating away from their units and treated water is not available, each soldier must produce his own potable water. To do this, he finds the best available source of water (para 6-2) and purifies it in his canteen, using either the standard issue iodine water purification tablets or the calcium hypochlorite ampules from the chlorination kit (para 6-3). Commanders should ensure that all members of their units are supplied with water purification tablets or ampules.

##### b. **Use of Iodine Tablets to Purify Water in a Canteen.**

(1) Before iodine tablets are used, they should first be checked for physical change, as they lose their disinfecting ability in time. Tablets that are not gray in color, which are stuck together, or which are crumbled should not be used.

(2) The following procedure is used in treating water in a canteen with iodine tablets:

- (a) Fill the canteen with the cleanest, clearest water available.
- (b) Add one iodine tablet to a one-quart canteen of clear water; add two tablets if the water is cloudy. Double these amounts for a two-quart canteen.
- (c) Place the cap on the canteen loosely. Wait 5 minutes and then shake the canteen well, allowing leakage to rinse the threads around the neck of the canteen.
- (d) Tighten the cap and wait an additional 25 minutes before using the water for any purpose.

c. **Use of Calcium Hypochlorite to Purify Water in a Canteen.** The following procedure is used to purify water in a one-quart canteen with calcium hypochlorite ampules:

- (1) Fill the canteen with the cleanest, clearest water available, leaving an air space of an inch or more below the neck of the canteen.
- (2) Fill a canteen cup half full of water and add the calcium hypochlorite from one ampule, stirring with a clean stick until this powder is dissolved.
- (3) Fill the cap of a plastic canteen half full of the solution in the cup and add it to the water in the canteen. Then place the cap on the canteen and shake it thoroughly.

**NOTE:** If an aluminum one-quart canteen is being used, add at least three capfuls of the calcium hypochlorite solution to the canteen, as this cap is much smaller than the one on the plastic canteen.

- (4) Loosen the cap slightly and invert the canteen, letting the treated water leak onto the threads around the neck of the canteen.
- (5) Tighten the cap on the canteen and wait at least 30 minutes before using the water for any purpose.

d. **Boiling of Water.** See paragraph 6-3e.

## 6-5. FIELD EXPEDIENTS

It is reasonable to anticipate that there will be times when, for one reason or another, water purification materials are not available to a small unit or to individuals in the field. A knowledge of field expedient methods of water purification may be extremely valuable in preventing disease due to contaminated water.

a. **Boiling.** Boiling, which was discussed in paragraph 6-3e, should be considered a field expedient measure which may be used within the limitations described.

b. **Commercial Household Bleaches.** Many commercial household bleaches contain approximately 5.25 percent sodium hypochlorite by weight. These products may be used to disinfect water. Instructions for this procedure are usually on the label. The dosages, however, tend to be lower than recommended military dosages. For field use, 6 drops of bleach are considered adequate for a canteen of water followed by 30 minutes contact time as when using the issue ampules.

c. **Tincture of Iodine.** Ordinary tincture of iodine may also be used to disinfect water. A dosage of eight drops in a canteen of water will provide an iodine dosage approximately equal to that of the issue iodine tablet. A 25-minute minimum contact time is required as with the tablet.

## Section II. FIELD WASTE DISPOSAL

### 6-6. GENERAL

The problem of waste disposal under field conditions differs from that of a garrison situation in two principal ways. First, the installation engineer exercises overall responsibility for all waste disposal facilities and services on the installation, whereas the commander of each unit in the field is responsible for waste disposal activities within his unit. The second major difference is that whereas installation waste disposal systems are of a permanent type, those in use in the field are generally temporary and improvised. It follows that units in the field cannot take waste disposal for granted as they tend to do in garrison. A lack of attention to waste disposal activities in the field can rapidly result in breakdown in sanitation.

### 6-7. MEDICAL IMPORTANCE OF WASTE DISPOSAL

The total weight of wastes of all kinds, including liquid wastes, produced under field conditions approaches 100 pounds per man per day. If this material were not removed promptly and thoroughly, a camp or bivouac would soon become a smelly, filthy dump. Filthborne diseases such as dysentery (amoebic and bacillary), typhoid,

paratyphoid, cholera, plague, and others might become prevalent. Flies, rats, and other vermin would increase and add to the individual's discomfort as well as endanger his health. Even with the relatively good sanitation maintained in the American Army camps of World War II, records show a total of nearly 1,000,000 hospital admissions for filthborne disease during that period.

## **6-8. DISPOSAL OF HUMAN WASTES**

a. Human wastes consist primarily of urine and feces. The accumulated excrement of a group of humans and animals will contain disease-producing organisms. This filth with its content of disease agents may enter the body in any of the following ways:

(1) From food, water, beverages, and eating utensils which may have been contaminated by feces, by the fingers of food handlers, or by flies and other vermin.

(2) From hands, when personal hygiene is not practiced.

(3) From close physical contact with unclean persons.

b. The basic principles in the control of filthborne diseases are:

(1) Prompt, thorough, and permanent disposal of urine and feces.

(2) Observance of the practices of personal hygiene, giving particular attention to cleanliness in finger habits, cleanliness of clothing, and cleanliness of hands and body.

(3) Prevention of the contamination of food, water, beverages, and eating utensils by fingers, flies and other vermin.

(4) Disinfection by boiling or by chemical means of eating utensils, food, and water which may have become contaminated.

c. The methods of human waste disposal will vary with the situation. Away from established bases, military units must adopt methods discussed below:

(1) On the march, the "cat hole" latrine is used. The individual digs a hole about a foot deep, then replaces and packs the earth over his excreta (figure 6-4).

(2) In temporary bivouacs of 1 to 3 days and in overnight camps, urine and feces are disposed of by the use of straddle trenches (see para 6-10).

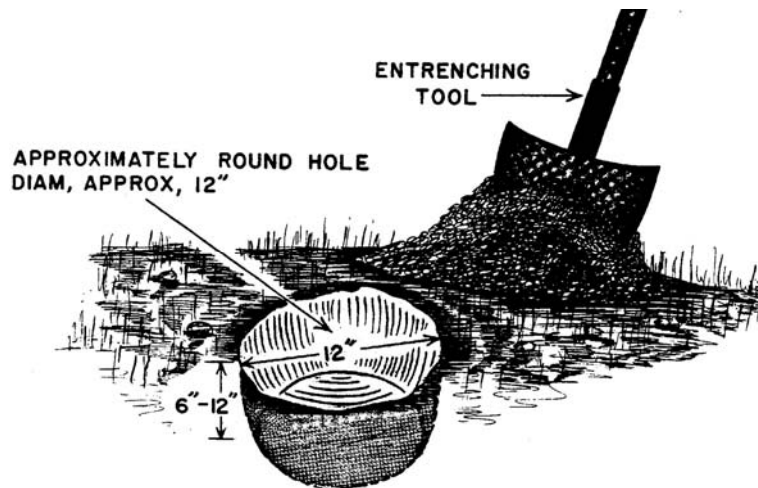

Figure 6-4. Cat hole.

(3) In temporary camps, deep pit latrines (see para 6-11) and urine soakage pits (see para 6-15) are usually constructed. Until the construction of deep pit latrines has been completed, straddle trench latrines may be used. Where the construction of deep pit latrines is not practicable, some of the other devices listed in this section may have to be used. Whatever the type used, the unit is responsible for its own latrine construction, maintenance, and closure.

d. The devices most generally used for disposal of human waste in the field are:

- (1) Straddle trench latrines (para 6-10).
- (2) Deep pit latrines (para 6-11).
- (3) Mound latrines (para 6-12).
- (4) Bored-hole latrines (para 6-13).
- (5) Pail latrines (para 6-14).
- (6) Urine soakage pits (para 6-15).

## 6-9. CONSTRUCTION AND CLOSING OF LATRINES

The following general rules apply to the construction of all types of latrines.

a. **Locations.** To make sure that food and water will be protected from contamination, latrines should be built at least 100 yards from the unit field food service facility and 100 feet from the nearest water source. Also, the latrine should not be dug below the water level in the ground nor in a place where it may drain into a water source. Usually, latrines are built at least 30 yards from the end of the unit area but



within a reasonable distance for easy access. At night, if the military situation permits, they should be lighted. If lights cannot be used, a piece of cord or tape may be fastened to trees or stakes to serve as a guide to the latrine.

b. **Screening.** A canvas or brush screen should be placed around each latrine or the latrine may be enclosed within a tent.

(1) In cold climates, this shelter should be heated if possible.

(2) The screen or the tent should have a drainage ditch dug around its edges to prevent water from flowing over the ground into the latrine.

(3) For fly control, shelters should be sprayed twice weekly with an approved insecticide. If a fly problem exists, also spray the pit contents and the interior of the boxes twice weekly with a residual insecticide.

c. **Handwashing Device.** A simple handwashing device should be installed outside each latrine enclosure (para 6-33). The device should be easy to operate and constantly supplied with water. The importance of handwashing devices must be given aggressive emphasis, since hands contaminated with fecal material are a common means of disease transmission.

d. **Policing.** Latrines should be policed every day. Certain unit personnel should be assigned the responsibility of ensuring that the latrines are being properly maintained.

e. **Closing.** When a latrine pit has been filled to within 1 foot of the surface or when it is to be abandoned, remove the latrine box and close as follows:

(1) The contents of the pit, the sidewalls, and the ground surface to a distance of two feet from the sidewalls should be sprayed with an approved residual insecticide.

(2) Then the pit should be filled to the ground surface with successive 3-inch layers of earth. Each layer is packed down and its surface is sprayed with insecticide before the next layer is added. Then the latrine pit is mounded over with remaining dirt to make a mound one foot high for the length of the pit and sprayed again with insecticide. The purpose of this method of closing is to prevent any fly pupae that may hatch in the closed latrine from getting out.

(3) Place a rectangular sign on top of the mound. The sign must indicate the type of pit and the date closed as well as the unit designation (in nonoperational areas).

## 6-10. STRADDLE TRENCH LATRINES

A straddle trench latrine is dug 1 foot wide, 2-1/2 feet deep, and 4 feet long. This will accommodate two men at the same time. The number of trenches provided should be sufficient to serve at least 4 percent of the male population and 6 percent of the female population at one time. Thus, for a unit of 100 men, at least 16 feet of trench or four 4-foot straddle trench latrines are needed (figure 6-5). The trenches should be at least two feet apart. There are no seats in this type of latrine, but boards may be placed along both sides of the trench to provide better footing. Toilet paper should be placed on suitable holders and protected from bad weather by a tin can or other covering. The earth removed in digging is piled at the end of the trenches and a shovel or paddle is provided. This is done so that each man can properly cover his excreta and toilet paper. When the unit leaves the area or when the straddle trenches are filled to within one foot of the surface, the trenches should be closed in the manner described in paragraph 6-9e.

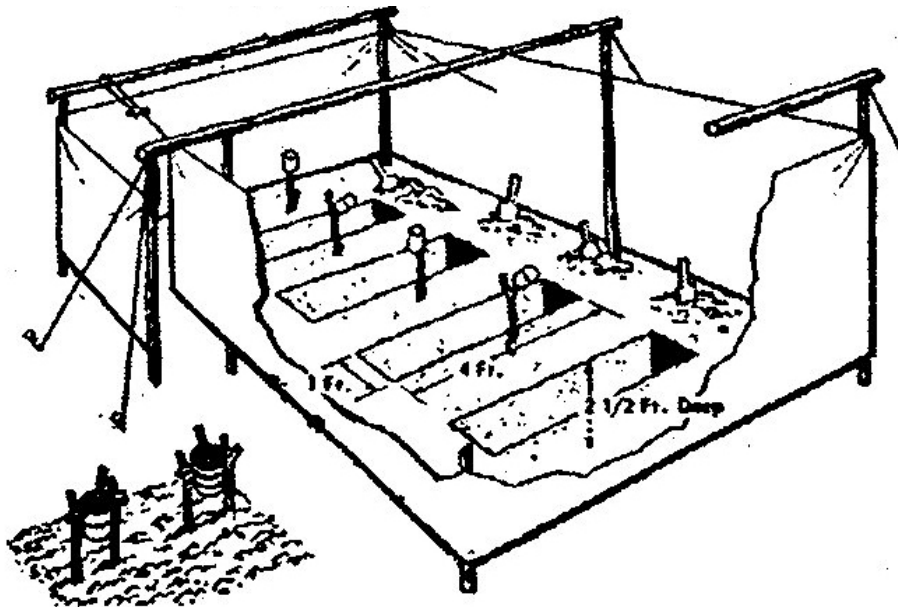

Figure 6-5. Straddle trench latrines for 100 men with screen and handwashing device.

## 6-11. DEEP PIT LATRINES

The deep pit latrine is used with a latrine box placed over it. The standard type box provides four seats and is 8 feet long and 2-1/2 wide at the base. A unit of 100 men requires 8 feet of latrine space or a 4-seat latrine box (figure 6-7). The hole should be covered with fly-proof, self-closing lids. All cracks should be fly-proofed with strips of wood or tin nailed over them. A metal deflector should be placed inside the front of the box to prevent urine from soaking into the wood. The deflector may be made with flattened cans.

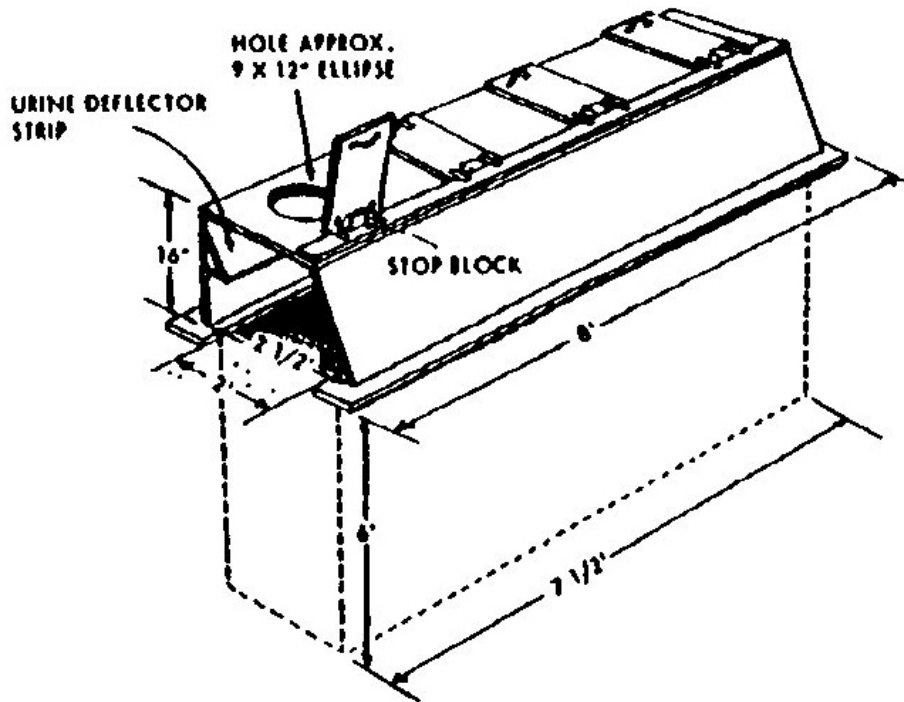

Figure 6-6. Deep pit latrine for 50 men.

a. **Construction.** The pit is dug two feet wide and 7-1/2 feet long. This will give the latrine box three inches of support on all sides. The depth of the pit will depend on the estimated length of time the latrine is to be used. As a rough guide, a depth of one foot is allowed for each week of estimated use plus one foot of depth for the dirt cover when closed. Generally, it is not desirable to dig the pit more than six feet deep because of danger that the walls may cave in. Rock or high ground water levels often limit the depth of the pit. In some types of soil, a support of planking or other material for the sides may be necessary to prevent wall cave-ins. Earth should be packed tightly around the bottom edges of the box so as to seal any openings through which flies might gain entrance.

b. **Sanitation.** In order to prevent fly breeding (deposit and hatching of eggs) in the pit and to reduce odors, it is necessary to keep the latrine box clean, the seat lids closed, and the cracks sealed; also, a good fly control program must be maintained in the area. The use of lime in the pit or the burning out of the pit contents is not effective for fly or odor control and should not be used. The box and the seats of the latrine should be scrubbed daily with soap and water. When a unit leaves the area or when deep pit latrines are filled to within one foot of the ground surface, the latrines should be closed in the manner described in paragraph 6-9e.

## 6-12. LATRINES USED IN HIGH WATER TABLE AREAS

The mound latrine and burn-out latrine may be used when a high ground water table or a rock formation near the ground surface prevents the digging of a deep pit. A discussion of each follows:

a. **Mound Latrine.** A dirt mound makes it possible to build a deep pit latrine and still not have the pit extending into the water or the rock (figure 6-7).

(1) Construction. A mound of earth having a top at least six feet wide and 12 feet long should be constructed so that a 4-hole latrine box may be placed on its top. The mound should be high enough to meet the pit's requirement for depth, allowing one foot from the base of the pit to the water or the rock level. Before the mound is built, the area where it is to be placed should be broken up or plowed in order to aid seepage of liquids from the pit. If timber is available, a crib of desired height is then built to enclose the pit and to help support the latrine box. The mound is then built and compacted in successive 1-foot layers until the top of the crib is reached as shown in figure 6-7. The surface of each layer is roughened before the next is added. If timber sufficient for building a crib is not available, the mound is constructed to the desired height in 1-foot layers as described. The pit is then dug into the mound. It may be necessary to brace the walls with wood, sandbags, or other suitable material to prevent cave-ins. The size of the base of the mound will depend on the type of soil in the area and should be made larger if the slope is too steep. It may be necessary to build steps up the slope.

(2) Fly-proofing and closing. The mound latrine should be fly-proofed in the same manner as is the deep pit latrine. It also is closed in the same manner as is the deep pit latrine.

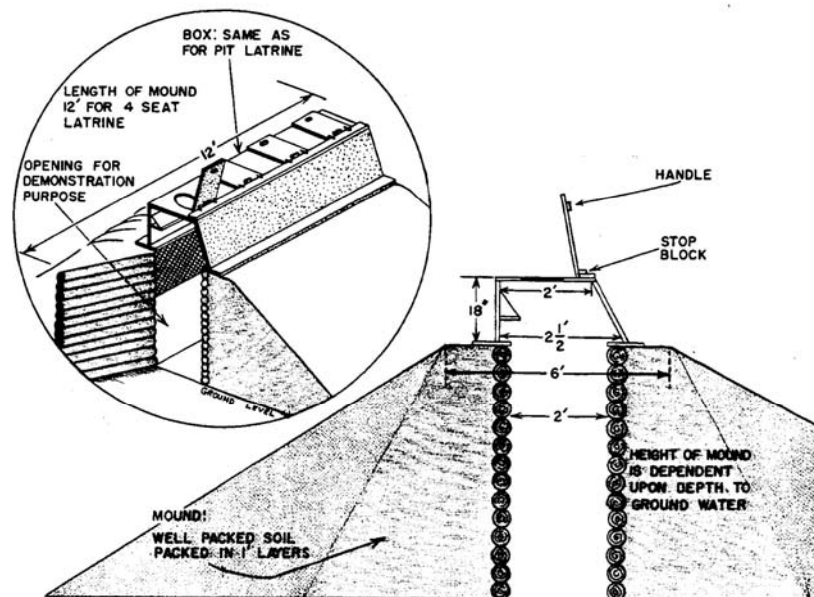

Figure 6-7. Mound latrine with timber crib.

b. **Burn-Out Latrine.** The burn-out latrine (figure 6-8) is particularly suitable to jungle areas with high water tables. It has been particularly successful in some parts of Vietnam. It should not be used, however, when air pollution regulations prohibit open fires. For a unit of 100 men, at least eight latrines are needed.

(1) Construction. A 55-gallon drum is placed into the ground, leaving enough of the drum above the ground for a comfortable sitting height. The drum may be cut in half, thus making two latrines of less capacity.

(a) A wooden seat with a fly-proof, self-closing lid is placed on top of the drum.

(b) If the drum must be moved to another site before the contents are burned out, handles should be welded to the sides to make it possible for two men to carry the drum with ease.

(c) It is convenient to have two sets of drums--one set for use, while the other set is being burned clean.

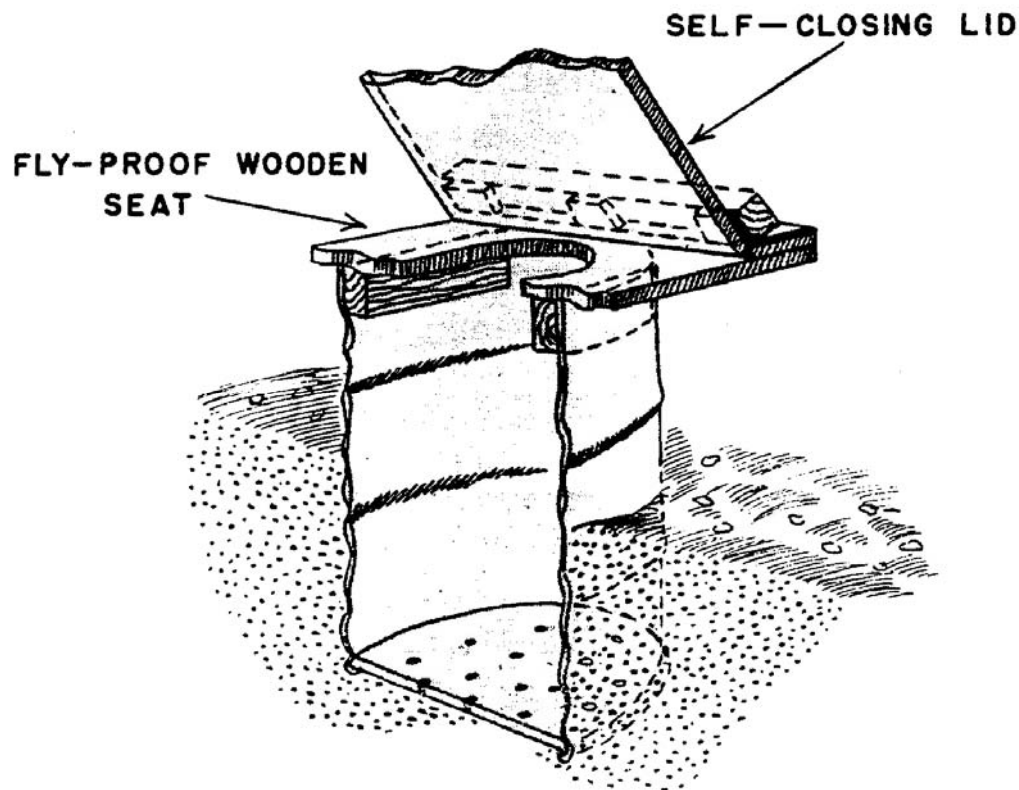

Figure 6-8. Burn-out latrine.

(2) Operation. The burn-out latrine should be burned out daily by adding sufficient fuel to incinerate the fecal matter.

(a) Highly volatile fuel such as gasoline or JP4 should not be used because of its explosive nature.

(b) A mixture of one quart of gasoline to five quarts of diesel oil is effective; nevertheless, it should be used with caution.

(c) Personnel should be encouraged to urinate in a urine disposal facility rather than in the burn-out latrine, as more fuel is required to burn-out one with the liquid content.

(d) If contents are not rendered dry and odorless in one burning, they should be burned again. The residual ash should be buried.

### 6-13. BORED-HOLE LATRINE

This type of latrine consists of a hole, about 18 inches in diameter and from 15 to 20 feet deep, covered by a one-hole latrine box (figure 6-9). The actual diameter is not critical; it should be made as large as available augers permit.

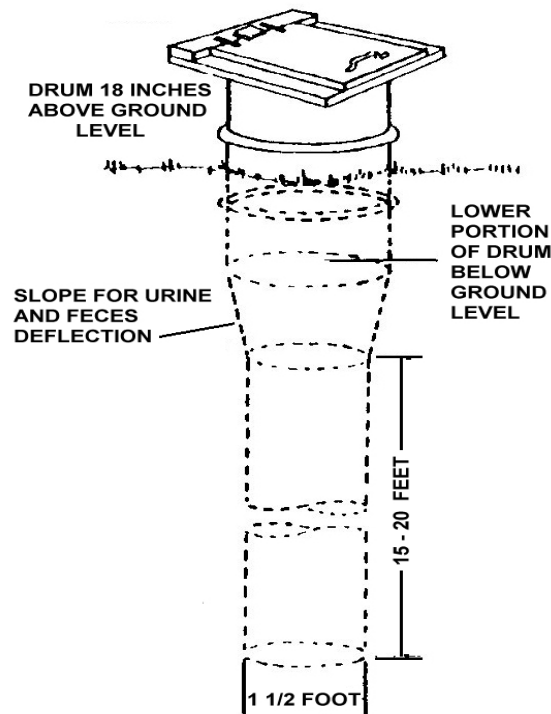

Figure 6-9. Bored-hole latrine.

a. A covered metal drum may be sunk into the ground for use as a box. Both ends of the drum are removed and a fly-proof seat cover with a self-closing lid is made to fit the top of the drum. If a drum is not available, a fly-proof wooden box, 18 inches high, may be constructed instead.

b. This type of latrine is satisfactory for small units, provided the necessary mechanical equipment for boring the hole is available.

#### 6-14. PAIL OR BUCKET LATRINE

A pail latrine may be built when conditions (populated areas, rocky soil, marshes) are such that a dug latrine cannot be used.

a. **Construction.** A standard type latrine box (para 6-11) may be converted for use as a pail latrine by placing hinged doors on the rear of the box, adding a floor, and placing a pail under each seat.

(1) If the box is located in a building, it should be placed to form a part of an outer wall so that the rear of the box opens directly to the outside of the building (figure 6-10). The seats and rear doors should be self-closing and the entire box fly-proof.

(2) The floor of the box should be made of an impervious material (concrete, if possible) and should slope enough toward the rear to facilitate rapid drainage of washing water.

(3) A urinal may also be installed in the latrine enclosure with a drainpipe leading to a pail outside. This pail also should be enclosed in a fly-proof box.

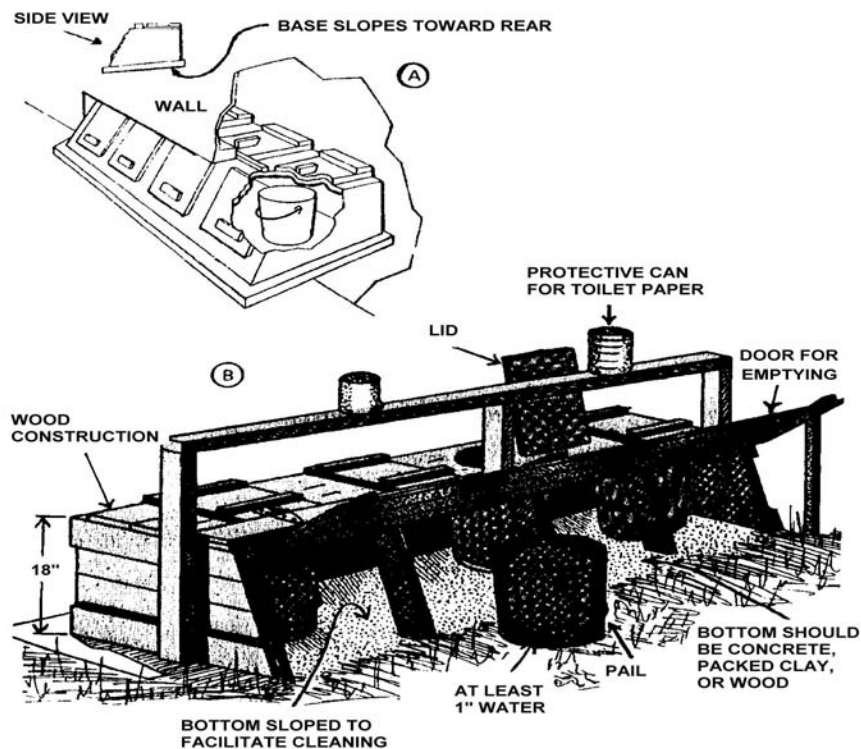

Figure 6-10. Pail latrine-- A in building; B in the open.

b. **Sanitation.** Pails should be cleaned at least once daily. The contents may be buried, burned, or disposed of by other sanitary methods. The use of plastic liners for pails reduces the risk of accidental spillage. Filled bags are tied at the top; then are disposed of by burning or burial.

## 6-15. URINE DISPOSAL FACILITIES

In permanent and semipermanent camps, urine disposal facilities are usually connected into the waterborne sewage system. In the field, separate devices for the disposal of urine may be necessary. Such facilities should be sufficient to accommodate 5 percent of the command at one time.

a. **Urine Soakage Pit.** The best device for urine disposal in the field is the urine soakage pit. This pit is dug 4 feet square and 4 feet deep; it is then filled with rocks, flattened tin cans, broken bottles, or other coarse contact material. A border 6 inches wide and 4 inches deep, composed of small stones or similar materials, is laid along each edge of the pit such that each side of the soakage surface is 5 feet in length. Depending on the materials available, either pipe urinals or trough urinals may be used with this pit. An optional feature is the ventilating shafts with screened openings extending from about 7 inches above to within 6 inches of the bottom of the pit.

b. **Pipe Urinals.** Five pipe urinals will be sufficient to serve the needs of a company of 100 men. Pipe urinals should be at least 1 inch in diameter. They should be placed at an angle near each corner of the pit and, if needed, on the sides halfway between the corners (figure 6-11). These pipes should extend at least 8 inches below the surface of the pit. A funnel of tar paper, sheet metal, or similar material is placed in the top of each pipe, the upper rim extending about 28 inches above the ground surface.

c. **Trough Urinals.** If the necessary materials are available and more permanent facilities are desired, a trough urinal may be built (figure 6-12). On the basis of accommodating 5 percent of a command at one time, 10 feet of trough length should be allowed for every 100 men in the command. This trough may be either U-or V-shaped and made of sheet metal or of wood. If made of wood, the trough should be lined with heavy tarpaper. Each of the four troughs forming the side of this urinal should be not more than 4-1/2 feet in length when used with a soakage pit and apron with the dimensions given in paragraph a above. Each trough should slope slightly toward one corner where a pipe is connected to carry the urine into the soakage pit.



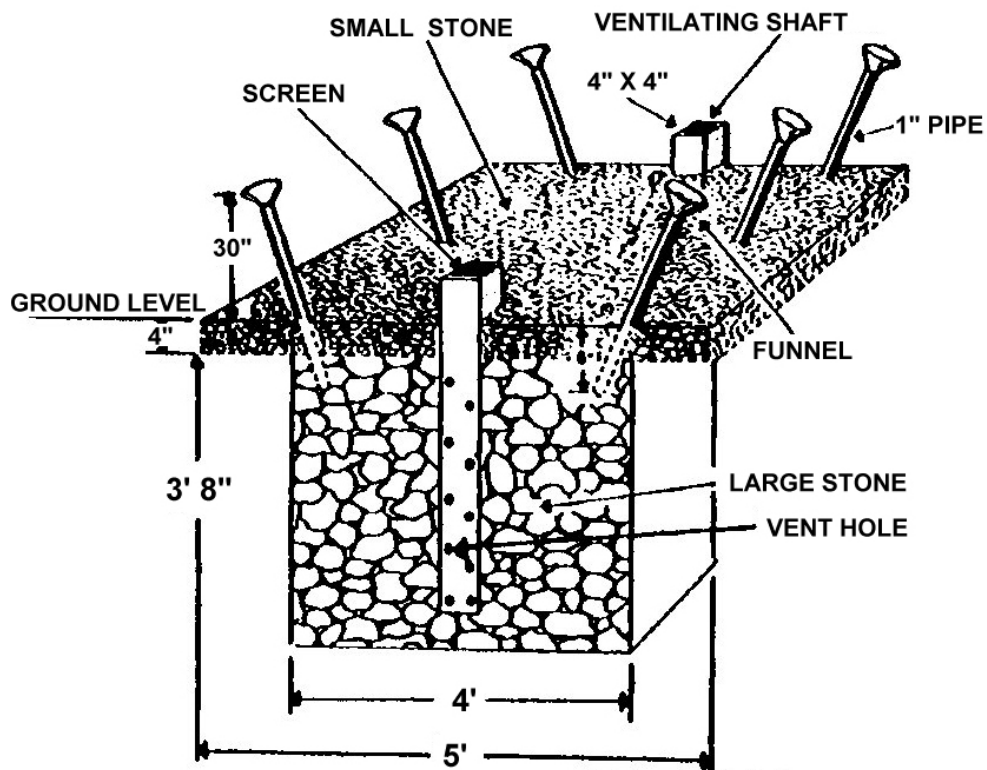

Figure 6-11. Urine soakage pit with pipe urinal arrangement.

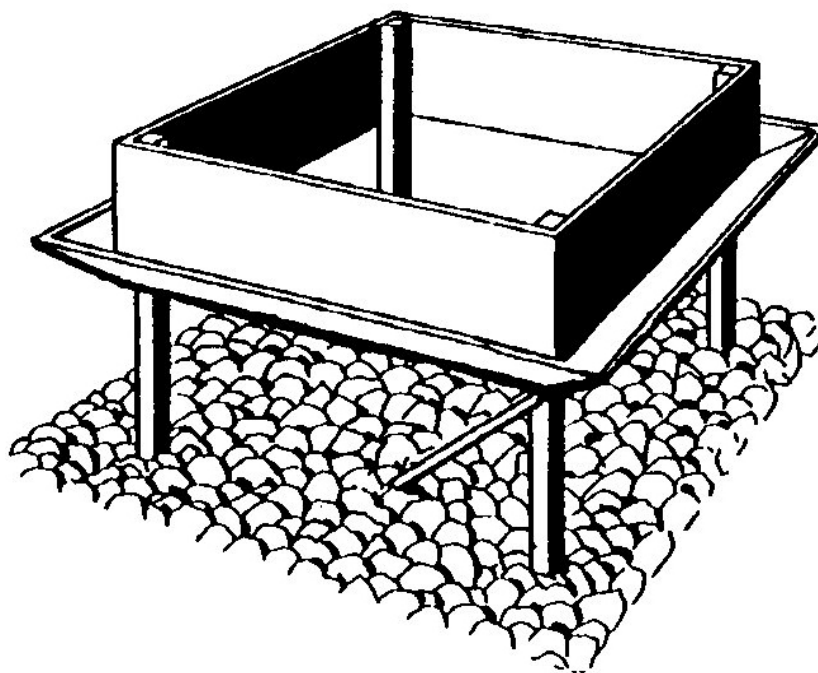

Figure 6-12. Trough urinal arrangement.

d. **Urinoil.** The urinoil (figure 6-13) represents a further modification for the more permanent installation. Simply described, it is a 55-gallon drum placed over a recessed soakage pit to receive and trap urine. The drum contains a quantity of waste oil, thus the name, urinoil. Urine voided through the screen and onto the surface of the oil immediately sinks through the oil to the bottom of the drum. The action of the urinoil is somewhat like that of a barometer. As more urine is added, the level rises within the 3-inch diameter pipe until it reaches the level of the notches in the 1-1/2 inch diameter overflow pipe in the center of the drum. The atmospheric pressure together with the weight of the oil causes the urine to overflow until an equilibrium is reestablished within the drum. The oil acts as an effective seal against odors and against the entrance of flies. The screen is easily lifted with attached hooks for removal of debris. The urinoil is operative in place as long as the soakage pit will accept the urine.

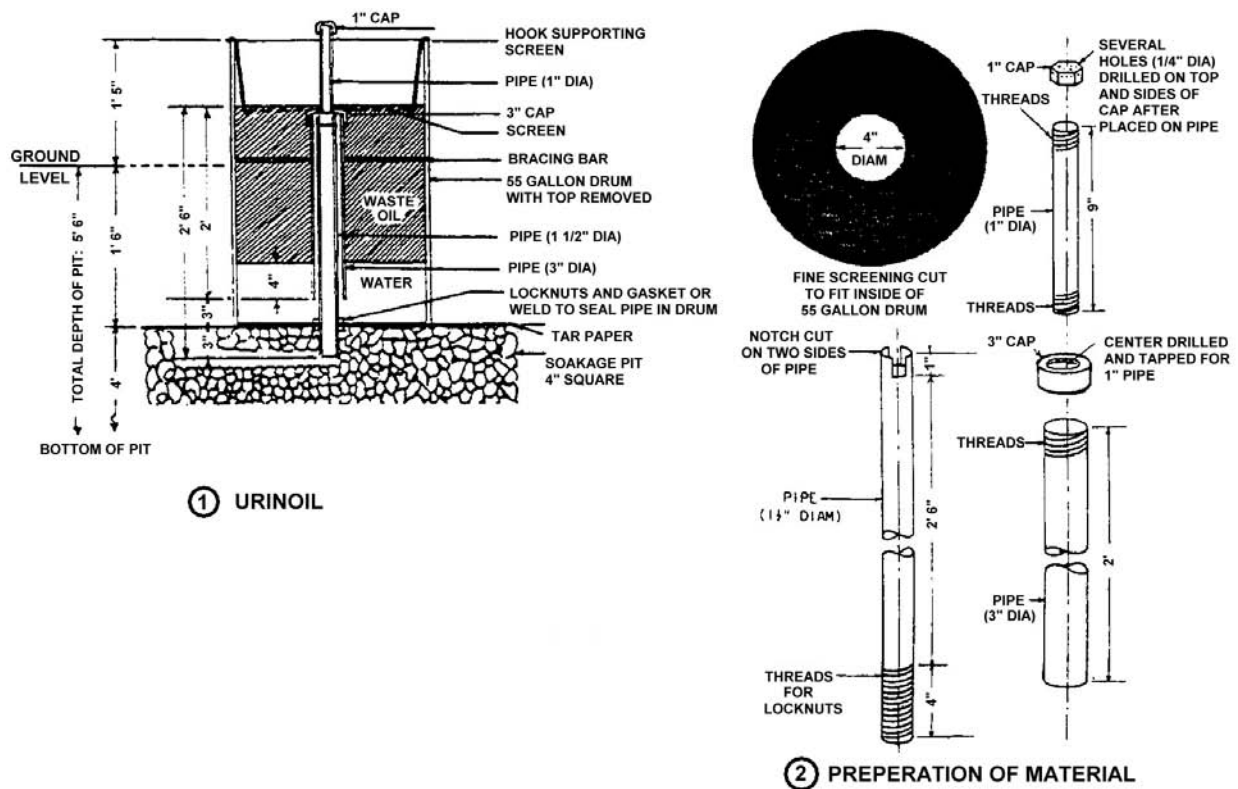

Figure 6-13. Urinoil.

## 6-16. OPERATION OF URINE DISPOSAL FACILITIES

In order to ensure the proper operation of these latrine facilities, the following procedures should be observed.

- a. Use the trough or the pipes--do not urinate on the surface of the pit.
- b. Wash funnels or trough daily with soap and water.

- c. Replace funnels when necessary.
- d. Do not let oil or grease get into the pit, as this may cause the pit to become clogged and thus necessitate the digging of a new one.
- e. If the latrine is located some distance from the sleeping area, a large can or pail may be placed at a convenient location in the area for use as a urinal at night. The can used for this purpose must be emptied into the soakage pit every morning and washed with soap and water before being reused.
- f. When a urine soakage pit is to be abandoned or has become clogged, it should be sprayed with insecticide and mounded over with a one-foot covering of compacted earth. Then a rectangular sign is placed on the mound indicating the type of pit and date closed. In nonoperational areas, the unit designation may also be included.

## 6-17. KITCHEN LIQUIDS

Liquid wastes from food service operations contain particles of food, grease, and soap. Consequently, this liquid requires some kind of treatment before it is allowed to drain into a sewer or is disposed of by other means.

a. **Grease Traps.** In permanent or semipermanent camps, this waste, after first having passed through a grease trap, drains into the sewerage system. In temporary camps, however, kitchen waste must be absorbed by the soil and here, too, grease traps (para 6-18) must be installed to take the grease from the liquid to prevent clogging of the soil and stopping absorption. These grease traps must be cleaned frequently and the removed grease either burned or buried.

b. **Soakage Pits.** In temporary camps, a soakage pit, constructed like a urine soakage pit (para 6-15a), normally will dispose of liquid kitchen wastes for a total of 200 persons. The only difference in the construction of urine soakage pits and kitchen waste soakage pits is that in the kitchen waste soakage pit, a grease trap is substituted for the pipes or troughs used in the urine soakage pit. If the camp is to last for several weeks, two kitchen waste soakage pits should be constructed, each pit to be used only on alternate days, since a rest period will help to prevent clogging. A soakage pit that has become clogged will not accept additional liquid; it should be abandoned and a new one constructed. When such a pit is to be closed, it should be mounded over with one foot of compacted earth and properly marked (para 6-16f).

c. **Soakage Trench.** If the ground water level or a rock formation exists close to the surface, a soakage trench may be used. This trench consists of a pit, 2 feet square and 1 foot deep, with a trench radiating outward from each of its sides for a distance of six feet or more (figure 6-14). These trenches are dug 1 foot wide and vary in depth

from 1 foot at the central pit to 1-1/2 feet at the outer ends. The pit and trenches are filled with material similar to that used in the soakage pit. Two such units should be built for every 200 persons fed, each unit to be used on alternate days. A grease trap should also be used with a soakage trench. A soakage trench is closed in the same way as a soakage pit.

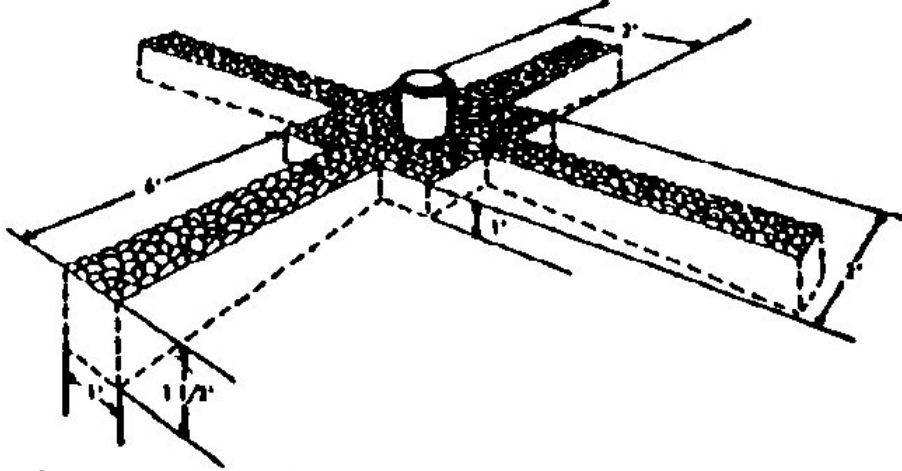

Figure 6-14. Soakage trench with barrel filter grease trap in place.

## 6-18. GREASE TRAPS

The grease trap should be of sufficient capacity so that the hot, greasy water being added will not heat the cool water already present in the trap. Otherwise, the grease will remain uncongealed and will pass through the trap. A grease trap is provided for each soakage pit except those under showers.

a. **Baffle Grease Trap.** A baffle grease trap may be made from half of a barrel which has been cut in two or from a box which has been divided vertically into unequal chambers by a wooden baffle (figure 6-15). This baffle should extend to within one inch of the bottom. The wastes are poured through a strainer into the larger chamber (about two-thirds of the capacity of the box or barrel); they then pass under the baffle and flow out of the smaller chamber. In the larger chamber, the trap should have a removable lid and a removable strainer. The strainer, which may be a box with openings in the bottom, is filled with straw or burlap to remove coarser solids; it must be cleaned frequently to prevent clogging. A one-inch pipe, inserted 3 to 6 inches below the top of the smaller chamber, acts as an outlet and carries the liquid from the trap to the soakage pit. To ensure proper operation of the trap, it must be cleaned frequently. Grease must be removed, the trap drained, and the sediment in the bottom removed. The removable strainer may be cleaned by scrubbing it with soap and water. The grease, sediment, and strainer material should be either burned or buried.

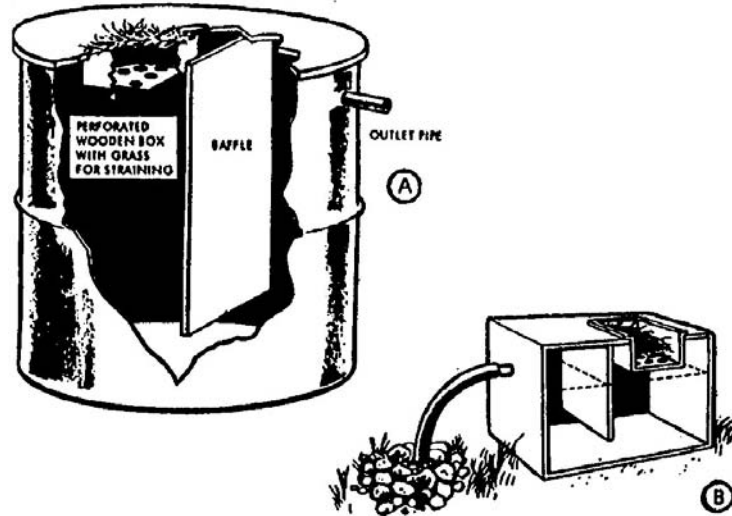

Figure 6-15. Baffle grease traps--A, barrel type; B, box type.

b. **Barrel Filter.** The barrel filter grease trap may be made from a 30 to 50-gallon barrel or drum which has had its top removed and a number of large holes bored into the bottom (figure 6-16). Eight inches of gravel or small stones are placed in the bottom and covered with 12 to 18 inches of wood ashes or sand. A piece of burlap is fastened to the top of the barrel to serve as a coarse strainer. The trap may be placed directly over the soakage pit or it may be placed on a platform with a trough leading to the pit. If it is placed directly over the pit, the bottom may be removed instead of having holes bored into it. Every two days, the grease trap should be emptied, washed, and refilled with fresh ashes or sand. The old ashes or sand should be buried. The burlap strainer should be either washed or renewed every day.

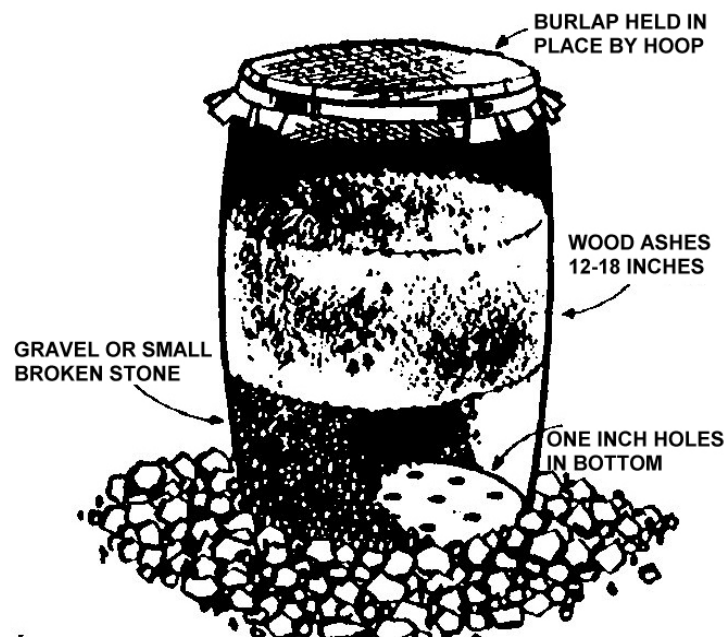

Figure 6-16. Barrel filter grease trap.

c. **Pail Strainer.** A pail strainer may be made by boring holes in the bottom of an old metal pail or can and filling it with grass or straw. This strainer will remove coarse particles of food and a small part of the grease. It may be used on top of the barrel grease trap instead of the burlap strainer.

## **6-19. OTHER WASTE WATER**

Every device that is used for washing or drinking in the field should have a soakage area of some kind under it to prevent pools and mud from forming. The area under and a few inches around individual handwashing devices, wash racks, and Lyster bags should be excavated a few inches and filled with small, smooth stones to form a soakage pit for spillage (figures 6-11, 6-12, 6-13, 6-14). Wastewater from wash racks should pass through a grease trap before it enters a soakage pit or soakage trench (figure 6-14). A soakage pit or soakage trench should also be used with each field shower device; however, no grease trap is required under showers.

## **6-20. DISPOSAL OF GARBAGE**

### **a. Burial.**

(1) On the march, in bivouac, or in camps of less than one week's duration, garbage is normally buried in pits or trenches. For this purpose, a pit four feet square and four feet deep is suitable for one day for a unit of 100 men. At the end of the day or when filled to within one foot of the surface, the pit should be sprayed with insecticide and filled in with earth and mounded over with an additional foot of compacted earth. Compacting the earth is very important; it helps deny flies and rodents access to the garbage that has been added during the day.

(2) Sometimes a continuous trench 2 feet wide and 4 feet deep may be used for the burial of garbage, the length of the trench depending on the length of time it is to be used. In the operation of this trench, the dirt that is removed to extend the trench is used to cover the garbage that has been added during the day.

(3) Pits or trenches should not be over 30 yards from the food service area. Garbage should not, however, be buried closer than 100 yards to any source of water used for cooking or drinking.

b. **Incineration.** Garbage and rubbish may be burned and reduced to an ash which may be used for fill, but the burial method is better and should be used whenever possible. If burial is not practicable, an incinerator may be constructed for use in the field.

(1) Since incinerators will not handle wet garbage, it is necessary to separate the liquid from the solid portion. This is done by straining the garbage with a coarse strainer such as an old bucket, salvaged can, or 55-gallon drum in which holes have been punched in the bottom. The solids remaining in the strainer are incinerated and the liquids are poured through a grease trap into a soakage pit or trench. Field incinerators should be located at least 50 yards downwind from the camp to prevent their being an odor nuisance.

(2) The inclined plan incinerator (figure 6-17) will dispose of the garbage of an entire battalion, evacuation hospital, or other unit of similar size.

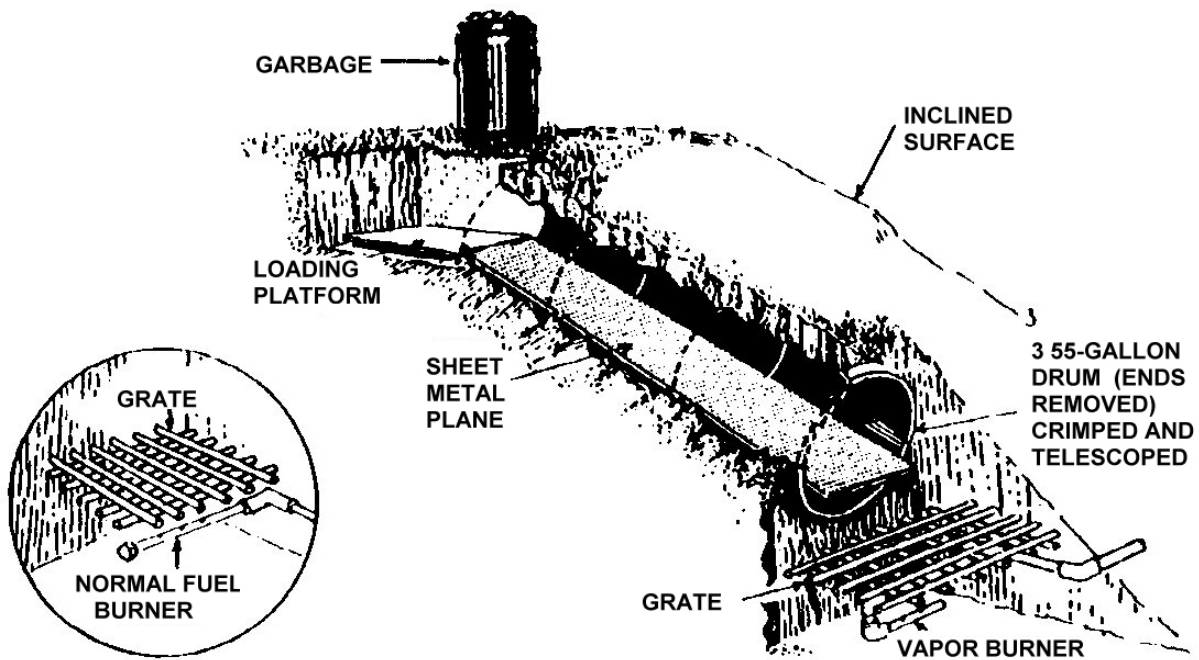

Figure 6-17. Inclined plan incinerator.

(a) A sheet metal plane is inserted through telescoped 55-gallon drums from which the ends have been removed.

(b) The metal plane should extend approximately 2 feet beyond the upper end of the telescoped drums to serve as a loading or stoking platform.

(c) The telescoped drums are positioned in an inclined surface.

(d) A grate is placed at the lower end of the telescoped drums and a wood or fuel oil fire is started under the grate.

(e) After the incinerator becomes hot, garbage is placed on the stoking platform. As the garbage becomes dry, it is pushed through the drums in small amounts to burn. Final burning takes place on the grate.

## 6-21. RUBBISH DISPOSAL

Rubbish or trash accumulated in the field consists mostly of wastes that originate at kitchens. It includes such items as emptied containers, waste paper, wood, metal, glass, ashes, and crockery. Rubbish is divided into two classes--combustible (that which can be burned) and noncombustible (that which will not burn).

a. At temporary camps or on bivouac, rubbish usually is buried in pits or in trenches with the garbage. If this is done, care should be taken to flatten tin cans and break down boxes before they are added to the rubbish. Flattening and reducing the volume of rubbish, together with adequate burial, helps prevent creation of rat harborages.

b. Should the unit be located near an ocean or an island, the rubbish and garbage may be disposed of by having it hauled out to sea and dumped. Several agencies of the Government are studying this method of rubbish and garbage disposal. Any changes occurring will be reflected in subsequent revisions.

c. A barrel incinerator (figure 6-18) is made from a 55-gallon drum by cutting out both ends, punching many holes near the bottom, and inserting grates inside the barrel several inches above the holes. The barrel is supported several inches above the ground on stones, brick, or dirt-filled cans, thus allowing space to build a fire under the barrel. In camps where the length of stay is over one week, the combustible rubbish is put into the barrel incinerator on the top grate.

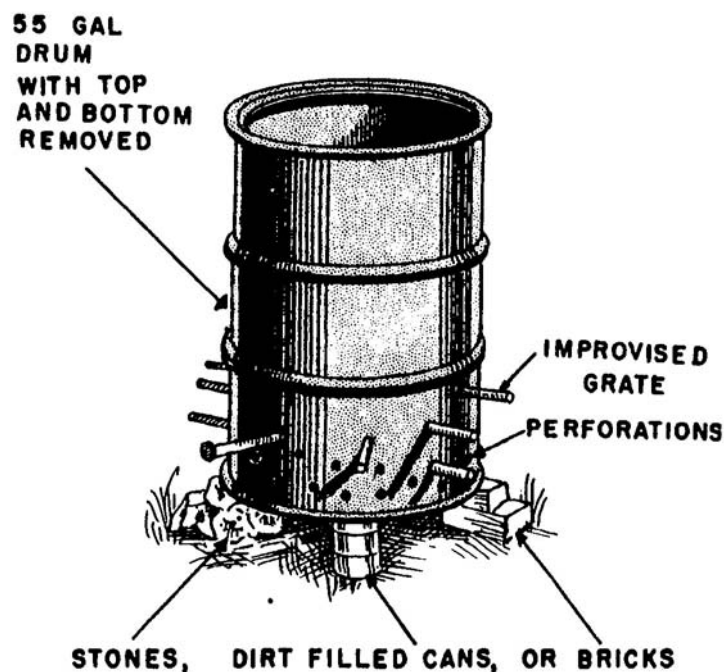

Figure 6-18. Barrel incinerator.



## **6-22. INFECTIOUS WASTE**

Infectious waste presents the same problems in the field as it does in garrison. In the field, however, the problem is more acute because of the limited facilities. Infectious waste requires meticulous collection and handling. Incineration is the only approved method of disposal. Because improvised incinerators are much less efficient than those of commercial design, they may not be satisfactory for moist combustibles. The inclined plane incinerator with a vapor-type burner, loading hopper, and platform at the top of the plane (figure 6-17) is the most efficient of the improvised incinerators-- particularly for wet combustibles; therefore, it is the recommended means for disposing of infectious waste.

### **Section III. FIELD SANITARY DEVICES**

## **6-23. GENERAL**

A discussion of field water supply and waste disposal would not be complete without the inclusion of field sanitary devices. Since the basic objective of providing safe water supplies and sanitary waste disposal facilities is the prevention of disease, sanitary devices cannot be over-looked. Field sanitary devices fall into two categories -- those that are for maintaining personal hygiene and those intended to keep food handling and service equipment in a sanitary condition.

## **6-24. CLEANING OF UTENSILS**

Food particles that are allowed to remain on food service utensils, whether used for cooking, serving, or eating, may serve as breeding places for germs. This is the reason for stressing the importance of thorough cleaning of food service utensils. The preferred method of disinfecting utensils is with hot water; however, in some instances in the field, hot water may not be available for cleaning cooking, serving, and eating utensils. Following are two procedures (with and without hot water) for washing the utensils of a unit in the field.

### **a. If Hot Water Is Available.**

- (1) Scrape utensils free of food particles and wash in warm water containing soap or detergent.
- (2) Rinse in clear, potable water.
- (3) Disinfect utensils by immersing them in clean water of 180°F for 30 seconds. If a thermometer is not available to determine the temperature of the water, heat the water to the boiling point.
- (4) Dry utensils in the open air and place them where they are protected against dust, splash, and other sources of contamination.

**b. If Hot Water Is Not Available.**

(1) Scrape utensils free of food particles and wash the utensils in water containing soap or detergent.

(2) Rinse in clear, potable water.

(3) Immerse for not less than 30 seconds in a chlorine solution. This solution is prepared by using "Disinfectant, Food Service" (NSN 6840-00-810-6396) as specified on the container. One package of disinfectant is dissolved in 25 gallons of water. When this material is not available, immerse for not less than 30 seconds in a chlorine solution containing at least one level messkit spoonful of high-test calcium hypochlorite (water treatment powder) in 10 gallons of water. If liquid chlorine bleach is available, it may be used. About one-third canteen cup of 5-percent chlorine bleach (NSN-6810-00-598-7316) to each 10 gallons of water will provide the same disinfecting strength. These quantities of disinfectant will ordinarily suffice for disinfecting the personal messkits of approximately 100 men. For greater numbers, fresh chlorine solution should be made up. The solution should be made up fresh for each period and should not be reused.

(4) Dry in the open air and place them as previously indicated (para a(4) above).

**6-25. INDIVIDUAL CLEANING OF MESSKIT**

a. **Equipment.** In the field, each individual ordinarily cares for his own messkit. Proper washing is important; otherwise, food particles will remain and become breeding places for disease germs. Three corrugated (G1) cans or other similar containers, placed in a row, are used for this purpose. Enough water is placed in each can to allow at least one quart of water per man or one wash line of three cans is provided for every 80 men. Large food service facilities may require several washing lines. The first G1 can contains hot, soapy water (150°F); the second and third cans contain clear water which is kept boiling throughout the washing period. A long-handled washbrush, a garbage can, or pit is also needed.

**b. Procedure.**

(1) Scrape the food scraps remaining in the messkit into the garbage pit or the garbage can.

(2) Wash the kit in the first container of hot, soapy water using a long-handled brush.

(3) Rinse the kit in the second can of clear, boiling water by dipping it up and down several times.

(4) Disinfect the kit by putting it in the third container of boiling water for several seconds.

(5) Remove the kit and shake it to remove the excess water. Allow it to dry in the air. Replace cover to keep out dust and vermin.

**c. Methods of Heating Water.**

(1) Immersion heater. This unit is the field-type water heater used most widely in the Army. It is standard equipment for all units organized under tables of organization and equipment. The heater is fired by gasoline and consists of a doughnut-shaped combustion chamber and a stack assembly welded together. A metal plate with operating instructions is located on the hinged hood that covers the top of the burner compartment. The unit is placed directly in the water that is to be heated (fig 6-19). It displaces approximately 12 gallons of water; thus, when used with a 32-gallon G1 can, it reduces the capacity of the can to 20 gallons.

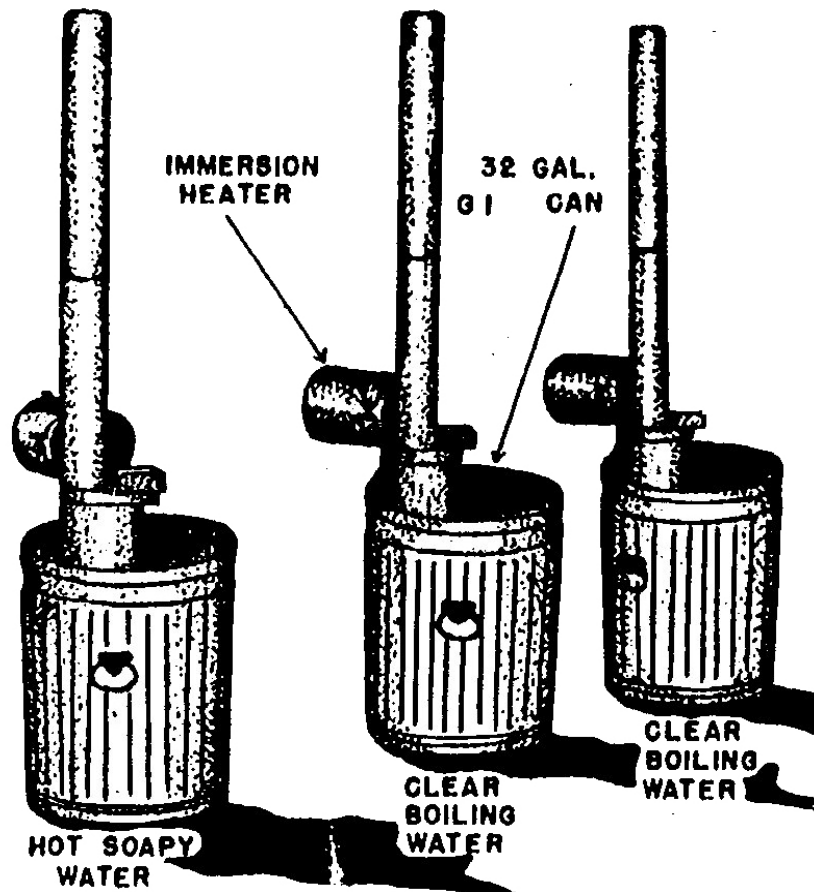

Figure 6-19. Messkit washline setup.

**CAUTION:** Do not operate heater within a building, tent, or other enclosed place unless exhaust fumes are piped outside.

(2) Improvised heater. When standard items either are not available or are insufficient in number to heat water properly, necessary devices must be improvised. Improvised methods of heating water in the field are described in subsequent paragraphs.

## 6-26. FIRE TRENCH

When solid fuels are plentiful, their use in a fire trench is one of the easiest methods for heating water (figure 6-20). The trench should be about one foot wide and one foot deep. Its length will depend on the number of water cans to be heated. For three cans, usually a trench 8 feet long is sufficient. The cans, supported by steel rods and pipes, are placed over the trench and the fire is built in the trench. This method uses a great amount of fuel and should be used only when wood or coal is abundant and a more efficient means is not available. If used for heating messkit wash water, the fire must be constantly attended to assure that the water in the second and third cans is kept boiling throughout use. In addition, cans are set near one side of the trench so users will not have to reach across the flames and possibly burn themselves.

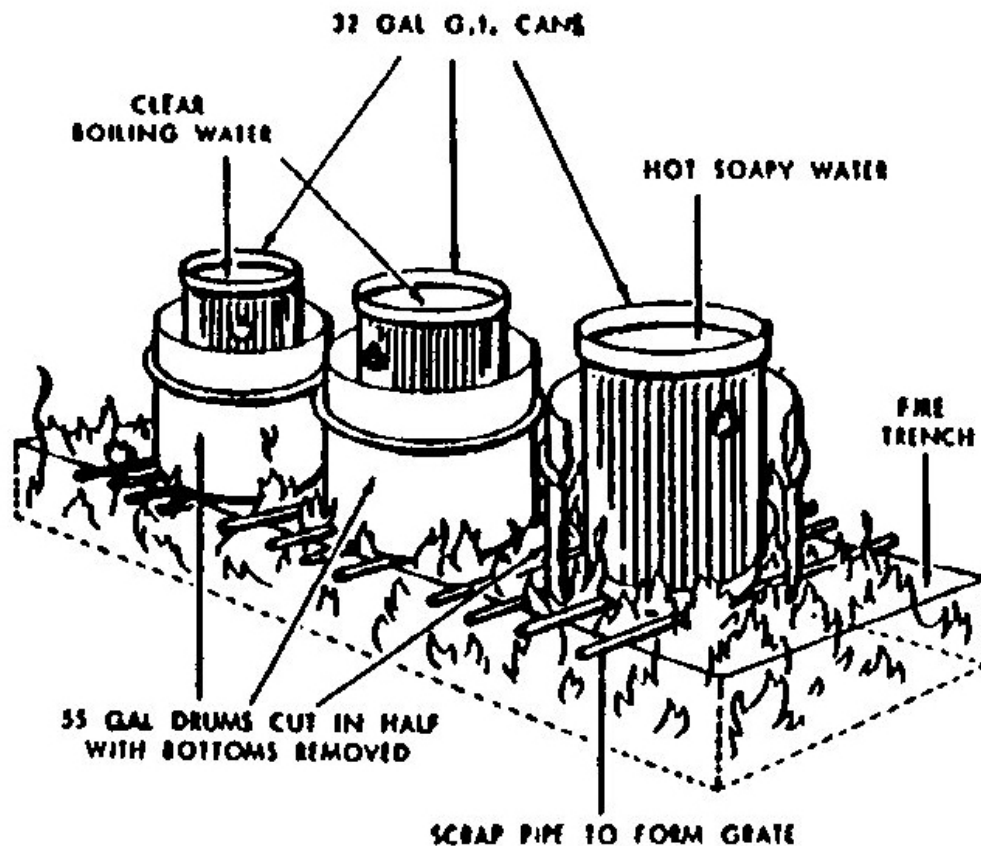

Figure 6-20. Messkit washline setup with fire trench.

## 6-27. OIL-WATER FLASH BURNER

a. **Description.** The oil-water flash burner uses diesel or motor oil as fuel. In cold climates, it may be necessary to thin these oils with gasoline or kerosene to obtain a good flow. The burner consists of a metal burner plate, a feed pipe, and containers for oil and water (figure 6-21). The containers are equipped with valves, taps, or plugs for controlling the rate of fuel flow and water flow.

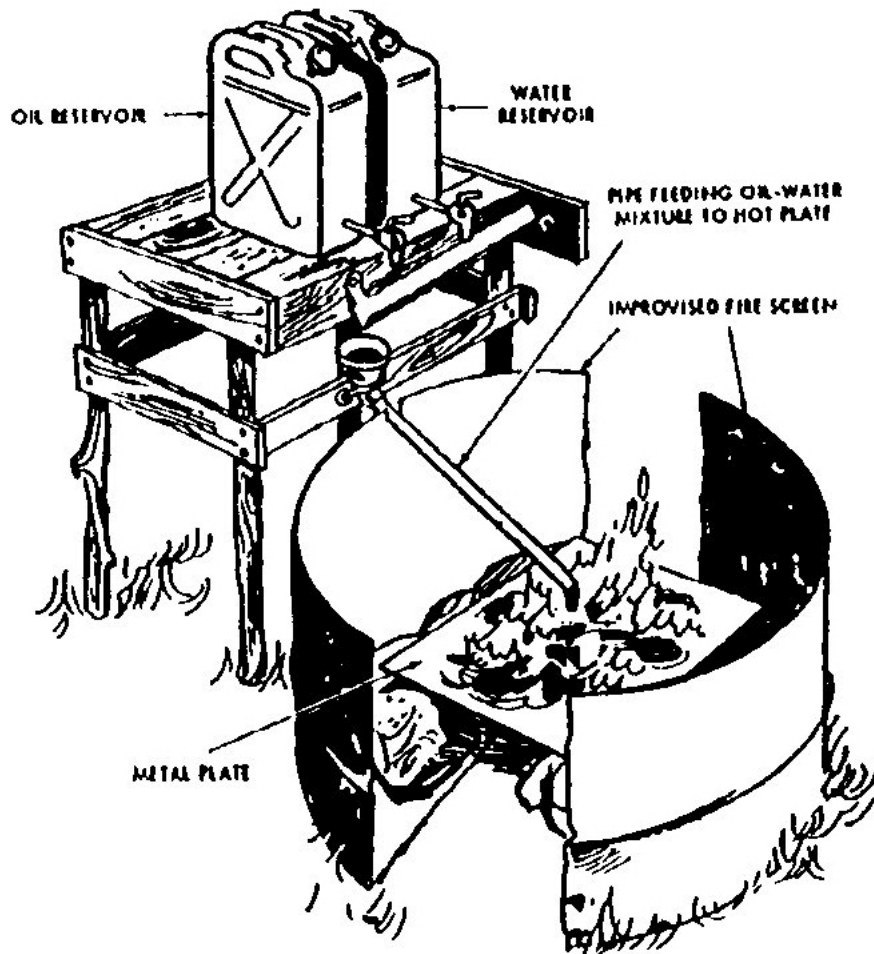

Figure 6-21. Oil-water flash burner.

b. **Operation.** Operation of this burner results from dropping a mixture of oil and water (generally about four parts of oil to one part of water) on a metal plate that has been preheated to the flash point of the oil. (Flash point is that temperature at which a liquid fuel bursts into flame.) The addition of water in small amounts increases the efficiency of this burner as the water becomes steam when it hits the heated plate. This steam aids burning by shattering the oil into very small droplets that will burn more readily than would larger drops of oil.

(1) The burner plate is preheated by burning waste material under it before adding the oil-water mixture. When the plate becomes hot, the oil-water mixture is allowed to drop slowly onto the plate. A hot flame may be obtained by adjusting the individual streams of oil and water. Very little smoke or odor is produced when the burner is operating properly.

(2) If waste motor oil is to be used as a fuel, it should be strained through a screen or cloth before it is added to the oil container to remove sludge and lumps that might block the drip valves.

(3) This burner is very sensitive to strong drafts, rain, or anything that will cool the plate. For this reason, it is not recommended for use in heating water for washing and sterilizing individual messkits. It is more appropriate for heating shower/bath water in the field.

(4) Shields should be on hand to protect the burner from wind and rain. If sheet metal for making these shields is not available, a simple protecting wall of stone or earth should be built.

## **6-28. VAPOR-TYPE BURNER**

A device that may be used to increase the efficiency of other improvised heating devices--particularly the inclined plan incinerator--the vapor-type burner.

a. **Description.** The vapor-type burner uses volatile liquids such as diesel oil, kerosene, gasoline, or a combination of these. As with the oil-water flash burner, it may be necessary in cold climates to thin the heavier fuels with gasoline before use.

(1) For the construction of this burner, it is necessary to have several sections of pipe, a valve, pipe fittings, and a fuel reservoir (figure 6-22).

(2) The operation of the vapor-type burner depends on vaporization of the fuel by preheating before burning. Burning of the fuel that escapes from the lower pipe of the burner heats the fuel in the upper pipe, causing the fuel to vaporize into a gas. This gas produces pressure in the lower pipe and forces the fuel out through small holes as a spray, thus producing a better flame.

(3) For best operation, the pipes should be placed in a fire trench. The trench should be about one foot wide and 15 inches deep.

(4) The pipe is assembled in such a manner that it is doubled under itself. The best size pipe to use is either one-half or three-quarters of an inch in diameter. Very small holes (1/16 inch or less) are drilled in the top of the lower pipe at points under the containers. The end of the pipe is capped so that fuel can escape only from the drilled holes. Properly constructed and operated, the vapor-type burner will boil water very efficiently.

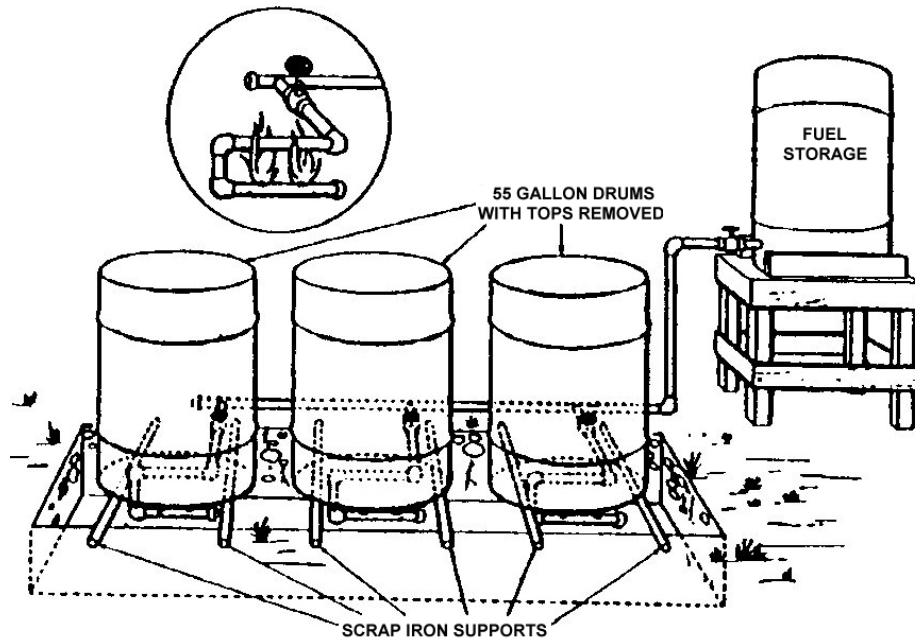

Figure 6-22. Vapor-type burner.

b. **Operation.** To operate the burner, the valve that controls the flow of fuel is opened to allow a small amount of fuel to run out through the holes in the bottom pipe. This fuel, when ignited, heats the upper pipe and starts the fuel-heat-gas pressure cycle described above.

(1) A properly operated burner will produce a blue flame. A yellow flame indicates incomplete burning; this is caused by too much fuel escaping from the holes and may be corrected by lowering the pressure in the line, either by reducing the size of the holes or by lowering the rate of the flow. If the flame is blue but tends to blow itself out, it indicates that the flow is too small. To correct this condition, increase the rate of flow in the line, either by enlarging the holes or by increasing pressure in the line.

(2) The pressure in the line is increased by raising--and decreased by lowering--the fuel container. A section of oil drum may be placed around the water container to direct the flame for better heating.

c. **Precautions.** The fuel reservoir must, of course, be elevated several feet above burners in order to supply adequate pressure and must not be allowed to become empty because flame from burners could flash back into the reservoir and cause an explosion.

## 6-29. MODIFIED M-1937 HEATER

a. **Description.** Modification of the heating unit from an M-1937 field range will permit its use to heat water for washing messkits. One heating unit can then be made to do the work of three. This modification consists of using a U-shaped pipe as shown in figure 6-23. The M-1937 heating unit is connected to the pipe by suitable fittings. At intervals of from 36 to 48 inches (sufficient to permit the cans of wash water to be set over them), three very small holes are drilled in the lower pipe. These holes should be about the size of a bristle in a wire brush. It is also important to provide perforated shields around the holes as shown. The shields can easily be made from number two size tin cans.

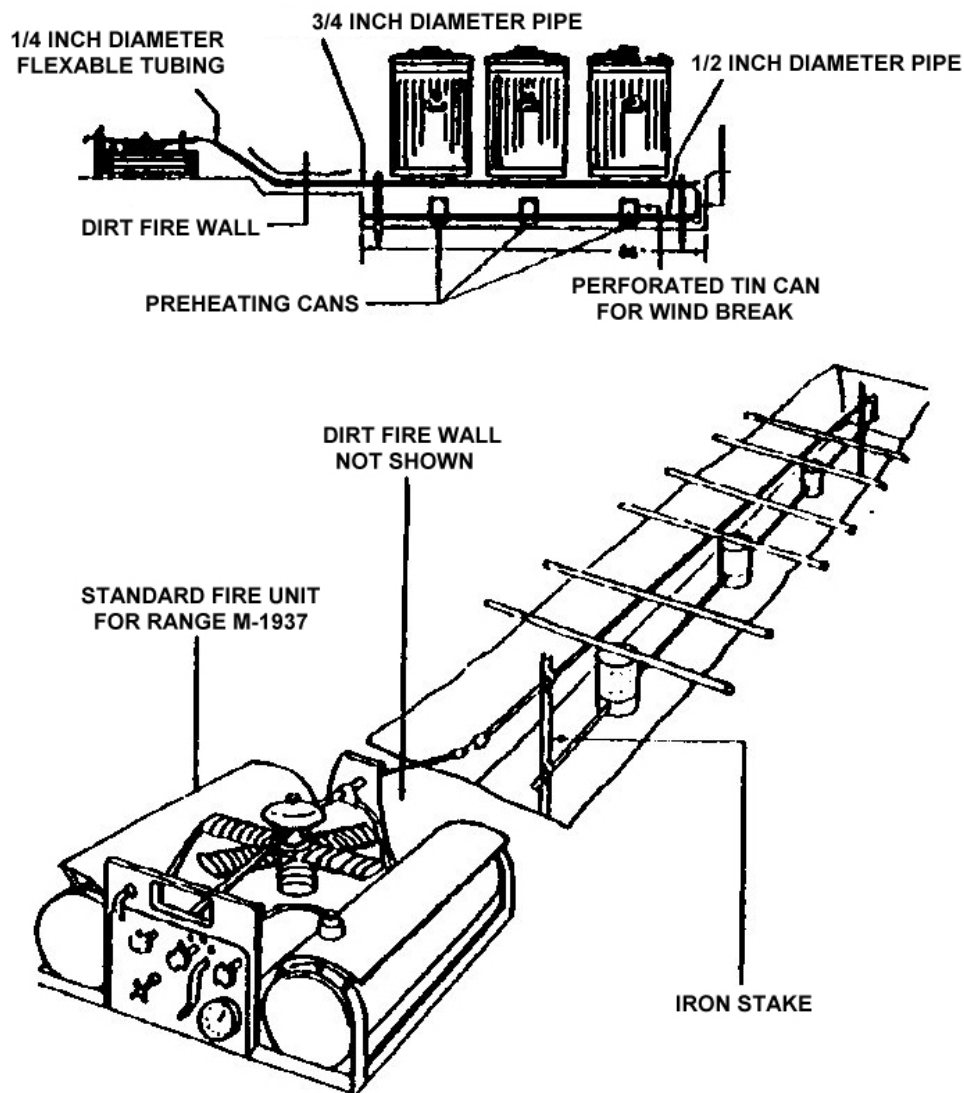

Figure 6-23. Modified M-1937 fire unit.



b. **Operation.** At the start of operation, the gas tank should be about 3/4 full and the pressure in the pressure tank pumped to about 45 pounds per square inch in warm weather or 60 pounds per square inch in cold weather (subfreezing). The portions of the lower pipe inside the shields and around the small holes should be preheated by igniting about a cupful of gasoline underneath them. This will also preheat the upper pipe. The control valve on the tank is opened about one-quarter turn; ignition will then occur and in two or three minutes, a steady blue flame will result. The burner control and air valves on the M-1937 unit remain closed.

### **6-30. OPERATION HAZARDS, HEATING DEVICES**

Whenever gasoline or oil heaters are used, there is potential danger of carbon monoxide poisoning, lead poisoning, or explosions; therefore, only experienced personnel should be permitted to operate improvised oil and gasoline burners.

a. **Carbon Monoxide.** Carbon monoxide is a colorless, odorless gas that is given off by the burner when combustion is incomplete. This hazard may be eliminated by proper operation of the equipment and adequate ventilation.

b. **Lead Poisoning.** Lead poisoning may result from the use of a leaded fuel, such as ethyl gasoline. The inhaling of vapors given off by the burner is particularly dangerous. Adequate ventilation, therefore, is absolutely necessary.

c. **Explosion.** Serious explosions may result from improper operation of these burners. This danger is not as great with the oil-water flash burner as it is with the vapor-type burner. If the flame goes out and the fuel is not turned off or relighted immediately, a dangerous concentration of gas will build up in the trench. If ignited, it will result in an explosion. For reducing explosion hazards with the vapor-type burner, an automatic relighting device may be improvised. This is done by wrapping a few coils of iron wire around the feed line and the burner line at the holes. After the burner has operated for a few minutes, this wire becomes red hot and if the flame goes out, the heat from the wire will relight the fuel. Also, the explosion hazard in the tank will be considerably decreased if the level of the fuel is not allowed to fall below the half-full mark.

### **6-31. IMPROVISED MESSKIT WASHING DEVICES**

After each meal, messkits should be cleaned and disinfected (para 6-25). In each of the devices discussed in this paragraph, three containers are required. When G1 cans are not available, messkit washing devices may be constructed from metal drums with tops removed (figure 6-22) or cut as described below. The vapor-type heater and the modified M-1937 heater work effectively with these devices.

a. **Drums Cut Crosswise.** Use the larger part (about two-thirds of the drum) as the water container. Cut out the end of the smaller part (about one-third of the drum) and use it as a support. This part may also serve as a shield for the burner. If the vapor-type burner is used, cut the bottom edge of the lower part of the drum so that it fits tightly around the pipe.

b. **Drums Cut Lengthwise.** In this setup, the drums are placed directly on a trench (figure 6-24). A chimney may be used to improve the draft of air. This will result in a hotter and cleaner fire.

c. **Drums Cut Two Ways.** When setting up a more permanent facility, a method in which the drums are cut in two ways may be used. The drums to be used as water containers are cut lengthwise so that one-third of the drum is removed. The drums to be used as supports are cut so that only one-fourth of the drum is removed. The drums are then fitted together and the sides of the supporting drums may be insulated with suitable materials. As this device operates best with the vapor-type burner, holes should be cut through the ends of the supporting drums near the bottom to permit the passage of burner pipes under the containers. Because of the close housing around the burners, this is a very efficient device.

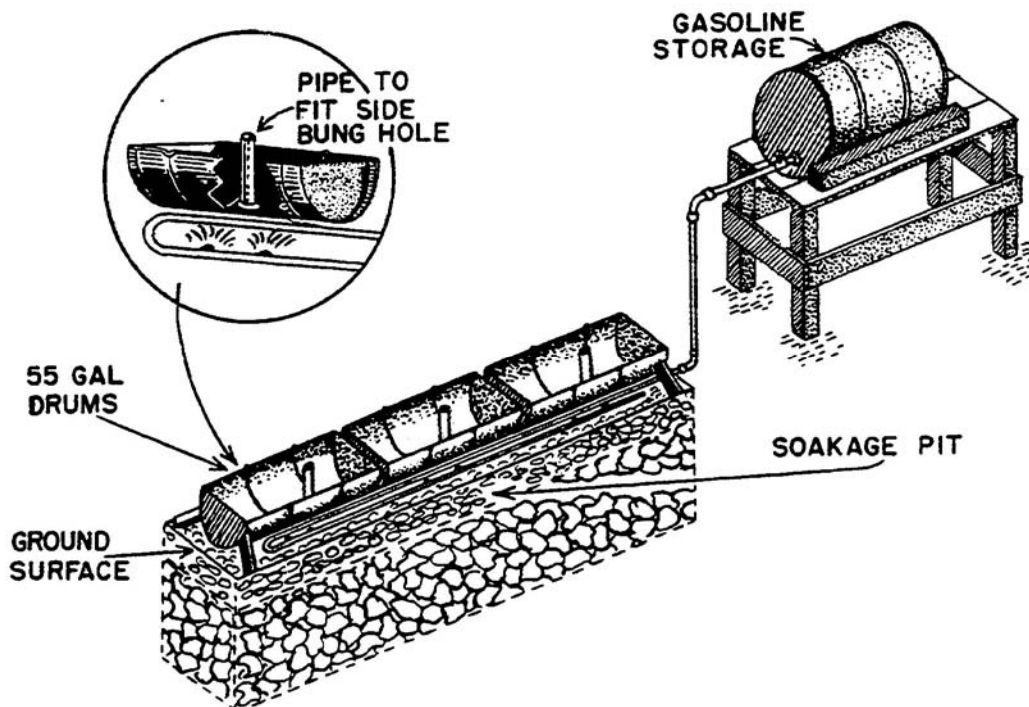

Figure 6-24. Improvised messkit washline setup.

## 6-32. DRAINAGE DEVICES FOR WASHING UNITS

As an aid in draining the washing units, one of the following devices may be used:

a. **Common Outlet.** Connect all three cans to one central outlet pipe. When the washing has been completed, the valve may be opened and the water drained out. The water so removed should be passed through a grease trap and then into a soakage pit.

b. **Bunghole and Pipe.** Cut a hole in the bottom of the drum and weld a pipe coupling into its place. Screw a short piece of pipe, about four inches longer than the depth of the water, into the fitting (figure 6-24). The pipe should be screwed in by hand so that it can be removed easily. When the drum is to be drained, the pipe is removed. With this arrangement, it is necessary to build a soakage pit under the device or to construct a trough under the containers and run the water into a grease trap and then a soakage pit.

## 6-33. IMPROVISED HANDWASHING DEVICES

Handwashing devices must be provided outside latrine enclosures and near or adjacent to kitchens. They may also be set up at other points in a bivouac area. To encourage their use, they should operate easily and should be kept filled with water at all times. Two cans should be provided and both containers checked frequently to see if refilling is needed. All of these devices should have a shallow area dug out under the outlet. The area should be filled with small stones. This soakage bed will prevent the water from gathering into pools. The simplest handwashing devices may be made from salvaged 5-gallon water cans or from number ten size food cans.

a. **Five-Gallon Water Cans.** When using five-gallon water cans, punch a hole in the cap and suspend the can from a support. By having the cans arranged as shown in figure 6-25, they may be tipped to permit a flow of water.

b. **No. 10 Size Food Can.** Figure 6-26 shows an improvised handwashing device that utilizes a perforated number ten food can as a sprinkler. This device is suitable for installation and use near latrines and messes. An improvised dipper may be made from a small food can plus wood, wire, or sheet metal for the handle.

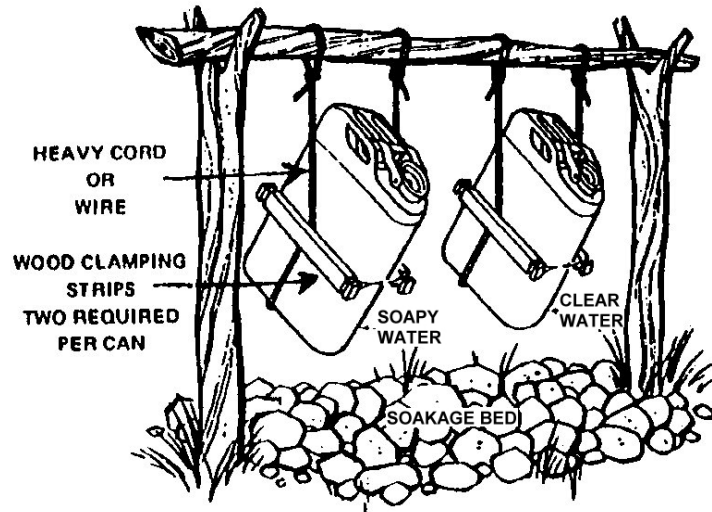

Figure 6-25. Handwashing devices using five-gallon water cans.

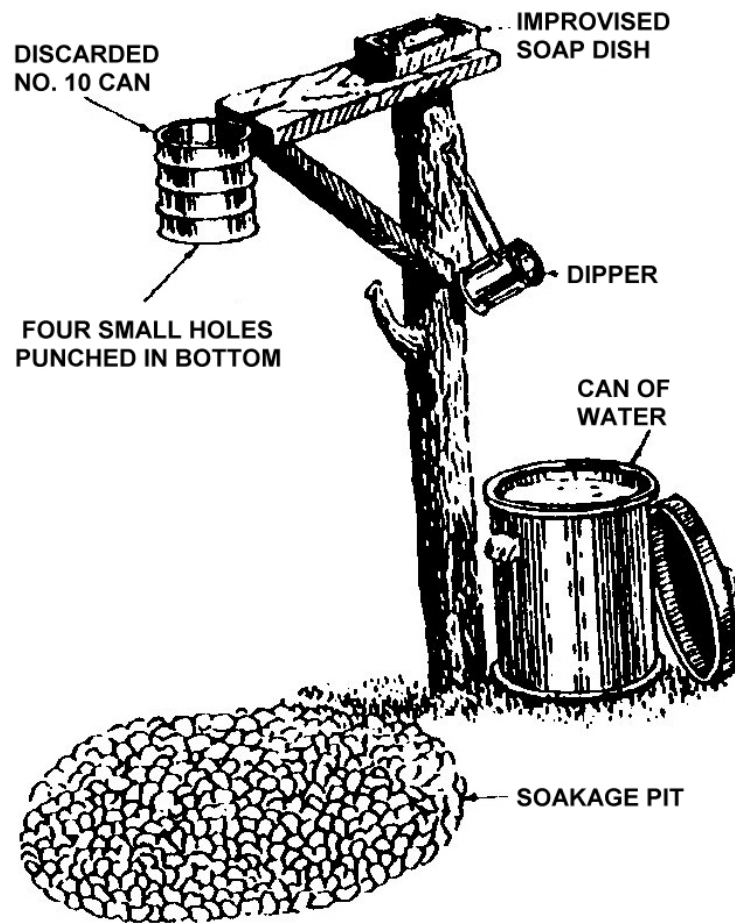

Figure 6-26. Handwashing device using number ten food can.

## 6-34. IMPROVISED SHAVING AND WASHING DEVICE

a. This device utilizes steel helmets as basins for hand washing, laundry, shaving, and other elements of personal hygiene. The structure can be built from salvage lumber or trees and branches. The center trough drains into the soakage pit and the center strip will support individual mirrors. The soakage pit will function better and last longer if protected by a grease trap.

b. When helmet racks (wash benches) are constructed, 10 feet should be allowed for every 100 men. This device should be used in connection with other sanitation devices as illustrated in figure 6-27.

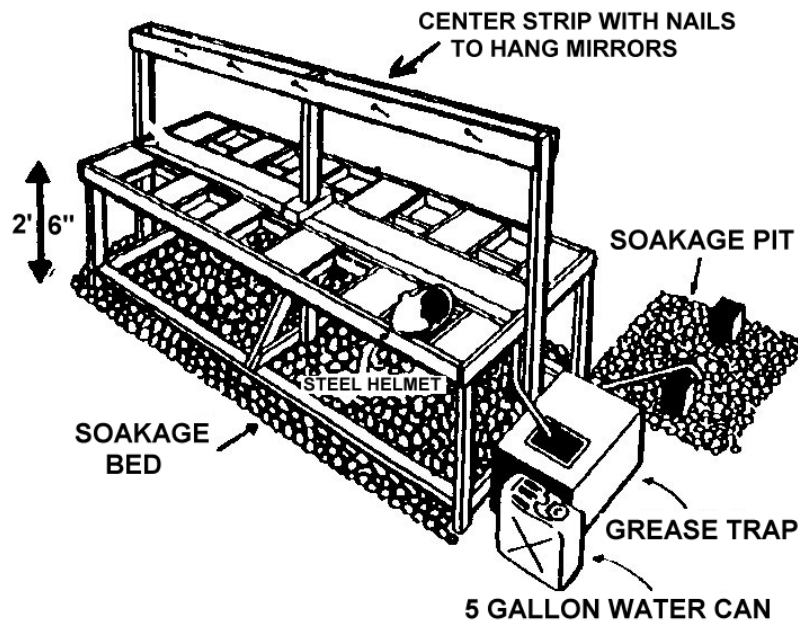

Figure 6-27. Improvised wash bench.

## 6-35. IMPROVISED SHOWER FACILITIES

Showers are important, not only for personal hygiene, but also as factors for maintaining the morale of a unit. In hot weather, heat from the sun may be used to take the chill from shower water. Painting water storage containers black or some other dark dull color will increase the absorption of heat from the sun. However, when large amounts of hot water are needed, man-made devices such as the water heaters previously described will be found necessary. There are many ways to arrange for showers when a unit is in the field. The devices shown here are but a few of those that have been improvised and found useful.

a. **Drum On Overhead Platform.** Figure 6-28 shows a metal drum placed on an overhead platform. Shower water is drawn off through an outlet fitted into the bunghole. A small can with one end removed and the other end perforated serves as a showerhead. A canvas or wooden cover helps reduce evaporation of water left in the drum to be warmed by the sun.

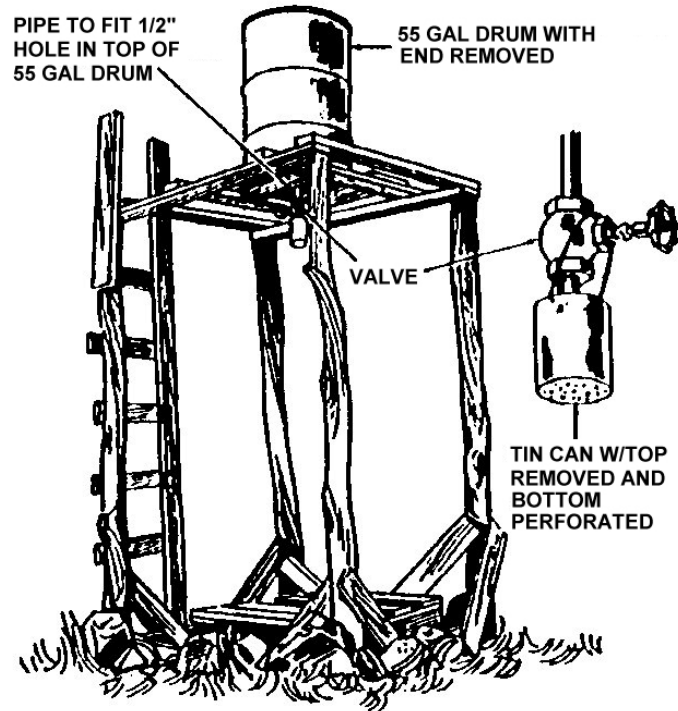

Figure 6-28. Shower unit using 55-gallon drum.

b. **Tilting Drum.** Another method of using the metal drum is shown in figure 6-29. In this shower, the drum itself has been perforated. Pulling down on the rope that is attached to the top of the drum tips the drum and operates the device.

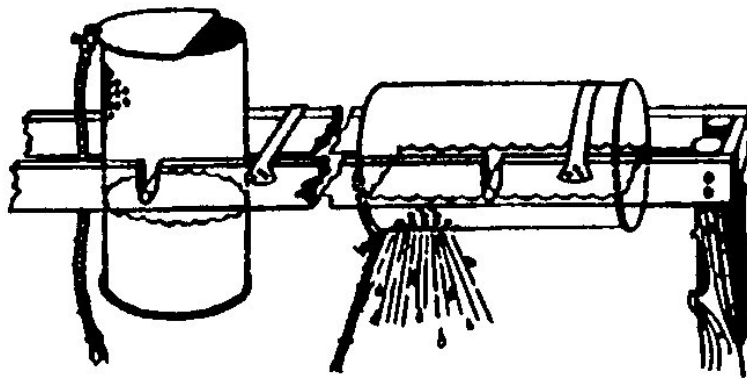

Figure 6-29. Tilting drum shower unit.

c. **Convection Type Setup.** A simple method of supplying hot water for showers is the convection type hot water heater shown in figure 6-30. With this arrangement, a mixture of hot and cold water is obtained for the shower. The water lines may be made from rubber tubing or from metal pipe. Heating the water in the lower container causes hot water to rise up the riser pipe. This hot water is replaced in the heating container immediately by an equal amount of cold water.

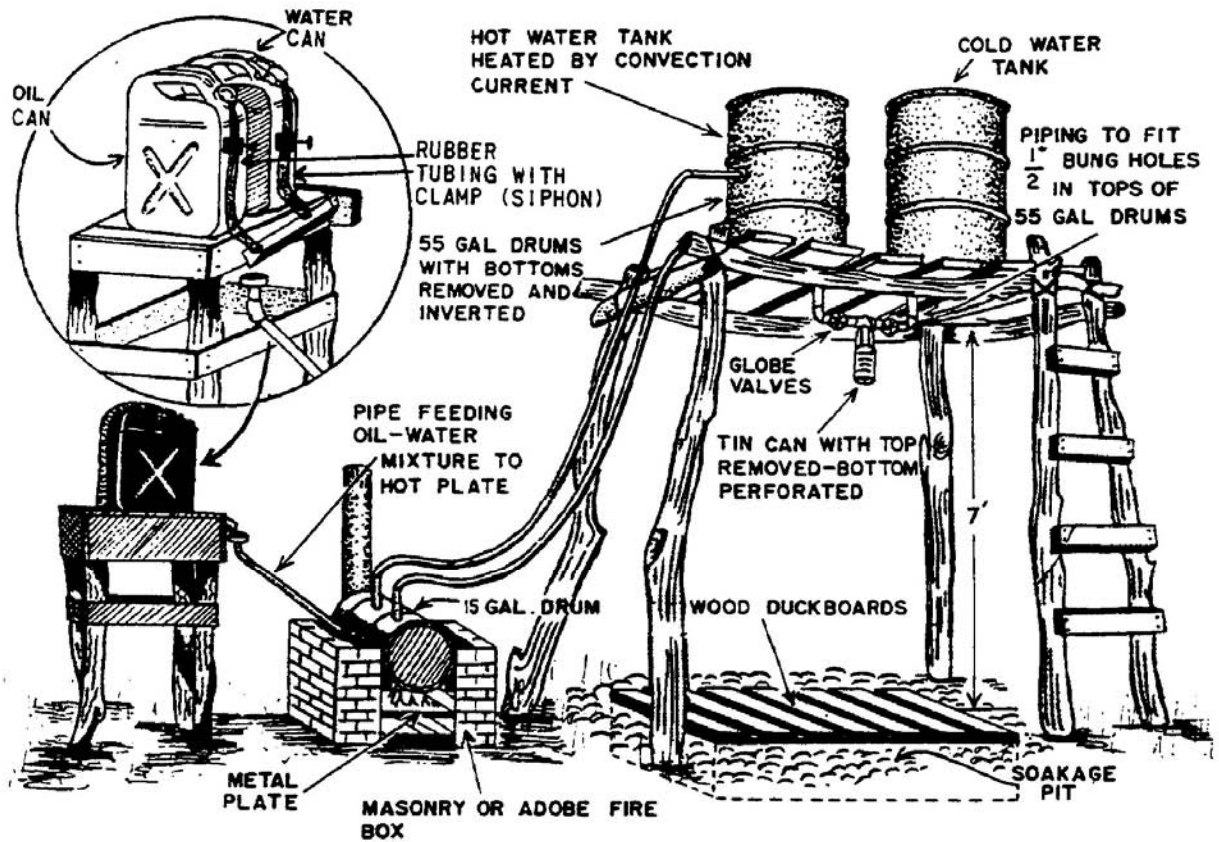

Figure 6-30. Improved shower heated with an oil-water flash burner.

[Continue with Exercises](#)

## EXERCISES, LESSON 6

**INSTRUCTIONS.** The following exercises are to be answered by marking the lettered response that best answers the question or best completes the incomplete statement or by writing the answer in the space provided.

After you have completed all the exercises, turn to "Solution to Exercises" at the end of the lesson and check your answers.

1. A water source that has been developed and established for military personnel in the field is known as a:
  - a. Water treatment facility.
  - b. Water utility station.
  - c. Watershed.
  - d. Water reconnaissance.
  - e. Water point.
  
2. Combat troops who do not have access to an approved source of water should select a source that:
  - a. Appears to be safe because the natives use it.
  - b. Is the most readily accessible.
  - c. Provides the most palatable water.
  - d. Provides the greatest quantity of water.
  - e. Is the easiest to purify.



3. Which of these water treatment procedures should you use before pouring raw water into a Lyster bag?
  - a. Add calcium hypochlorite to the water.
  - b. Add orthotolidine to the water.
  - c. Stir the water vigorously.
  - d. Let mud and other debris settle out of the water.
  - e. Add iodine tablets to the water.
  
4. Small units in the field purify water using the:
  - a. Erdlator.
  - b. Immersion heater.
  - c. Chlorination kit.
  - d. Color comparator.
  
5. Orthotolidine tablets are used to:
  - a. Chlorinate water.
  - b. Determine the disinfecting time.
  - c. Determine the chlorine residual of water.
  - d. Disinfect water.

6. After adding an ampule of calcium hypochlorite to water in a Lyster bag, you wish to determine the chlorine residual using the five parts per million (ppm) plastic comparator tube. You test a sample with orthotolidine and find that the yellow color in the sample is lighter than the yellow band around the top of the tube. This tells you that the chlorine residual is:
  - a. More than five ppm.
  - b. Exactly five ppm.
  - c. Less than five ppm.
  - d. At least one ppm.
  
7. As they deteriorate, iodine tablets change color. Tablets effective in treating water are:
  - a. Light yellow.
  - b. Brown.
  - c. Steel gray.
  - d. Dark reddish brown.
  
8. What number of iodine tablets is used to purify a quart canteen full of unclear water for drinking purposes?
  - a. One.
  - b. Two.
  - c. Three.
  - d. Four.

9. Which of the following may be used to purify water if standard issue iodine tablets or calcium hypochlorite ampules are not available? (More than one answer may be correct.)
- a. Alcohol.
  - b. Household bleach.
  - c. Sodium bicarbonate.
  - d. Household detergent.
  - e. Tincture of iodine.
  - f. Hot water.
10. When away from his bivouac or campsite, an individual should dispose of his excrement by means of a \_\_\_\_\_.
11. In temporary camps and bivouacs of short duration (one to three days), \_\_\_\_\_ latrines are used.
12. In closing a latrine, the pit should be covered with successive layers of earth \_\_\_\_\_ inches thick. Each layer should be \_\_\_\_\_ before the next layer is added.
13. A unit of 150 men requires approximately \_\_\_\_\_ feet of latrine space.
14. When a high water table or extremely rocky earth precludes the use of a deep pit latrine, a unit in the field may construct either a \_\_\_\_\_ or \_\_\_\_\_ latrine.
15. When a temporary latrine must be set up in a building or where digging is impracticable, a \_\_\_\_\_ latrine may be used.

16. How many pipe urinals are required for a unit of 200 men?
- Five.
  - Ten.
  - Fifteen.
  - Twenty.
17. Kitchen liquids should be passed through a \_\_\_\_\_ before being allowed to enter a soakage pit.
18. If the water table or rock formations are near the surface, a \_\_\_\_\_ may be used in lieu of a soakage pit.
19. Infectious waste should be disposed of in the field by:
- Burial with kitchen wastes.
  - Burning in a barrel incinerator.
  - Burial with the contents of latrines.
  - Burning in an inclined plane incinerator.
20. In the field, washing with soap and hot water is the \_\_\_\_\_ method of cleaning utensils.
- Only acceptable.
  - Preferred.

21. Washed messkits should be dried by what means or method?
- Wiping.
  - Heating.
  - Blotting.
  - Exposure to air.
22. A messkit wash line setup for 120 men requires:
- Two three-can setups or six cans.
  - Three cans, each containing 30 gallons (120 quarts) of water.
  - Five cans, each containing 20 gallons (80 quarts) of water.
  - Four cans containing 20 gallons (80 quarts) each and a fifth containing 10 gallons (40 quarts) of water.
23. The efficiency of an inclined plane incinerator or an improvised heating device may be increased by the use of a:
- Fire trench.
  - Vapor-type burner.
  - Scrap iron grate.
  - Modified immersion heater.
24. Rays of the sun may be utilized to assist in heating water by:
- Storing the water in glass containers.
  - Storing the water in aluminum or stainless steel containers.
  - Painting storage containers black.
  - Painting storage containers white.

**Check Your Answers on Next Page**

## SOLUTIONS TO EXERCISES, LESSON 6

1. e (para 6-1a)
2. e (para 6-2b)
3. d (para 6-3a)
4. c (para 6-3e(1))
5. c (para 6-3b(1))
6. c (paras 6-3b, c)
7. c (para 6-4b)
8. b (para 6-4b)
9. b  
e (paras 6-5b, c)
10. (para 6-8c(1); figure 6-6)
11. (para 6-8c(2); figure 6-7)
12. Three, sprayed with insecticide. (para 6-9e (2))
13. 1. (paras 6-10, 6-11)
14. Mound, burn-out. (para 6-12)
15. Bucket (pail). (para 6-14)
16. b Ten. (para 6-14b)
17. Grease trap. (para 6-17a)
18. Soakage trench. (para 6-17c)
19. d (para 6-22)
20. b (para 6-24)

21. d (paras 6-24a(4), b(4))
22. a (para 6-25a)
23. b (para 6-23)
24. c (para 6-34)

**End of Lesson 6**

## LESSON ASSIGNMENT

### LESSON 7

Military Medical Entomology Field Control.

### LESSON ASSIGNMENT

Paragraphs 7-1 through 7-20.

### LESSON OBJECTIVES

After completing this lesson, you should be able to:

- 7-1. Given a list, select the Military significance of entomology.
- 7-2. Given a list, select seven ways in which arthropods cause direct injury to humans.
- 7-3. Given an arthropod vector and/or an arthropod-borne disease, select the vector and/or disease.
- 7-4. From a list, select the capabilities and areas of responsibilities in entomology field control for the Field Sanitation Team, Preventive Medicine Team, Preventive Medicine Activity and Facility Engineers.

### SUGGESTION

After completing the assignment, complete the exercises at the end of this lesson. These exercises will help you to achieve the lesson objectives.



## LESSON 7

### MILITARY MEDICAL ENTOMOLOGY FIELD CONTROL

#### 7-1. INTRODUCTION

It is impossible to review military and world history without considering arthropod-borne diseases. At times, effects from arthropod-borne diseases have outweighed battle casualties. Commanders seem to forget these bitter lessons. Commanders may become forgetful in time of war when other matters seem more urgent. Because the commander is responsible for troop health, he may ask for advice on certain disease problems. Hence, you must be familiar with arthropod-borne diseases and be convinced of applicable individual and unit protective measures (Table 7-1).

#### 7-2. MILITARY SIGNIFICANCE

Entomology is especially important in today's Army. Since we are very mobile and deployable at anytime to any place in the world, we need to be very careful of contact with arthropod-borne diseases. When working with guerrilla-type warfare, we again expose ourselves to possible illness. We, as a susceptible population, can only rely on things like immunizations, sanitation, and education to try and maintain some kind of an edge.

#### 7-3. EFFECTS OF ARTHROPODS

Arthropods can affect our health in many ways, the most important being bites. Many insects bite, some in self defense, some just chew but the ones which cause the most trouble are the ones that use us as a food source. They have mouthparts that are capable of piercing the skin and sucking out blood and other fluids. During the bite, they introduce chemicals that may be severe irritants, but that is not half the problem. When those insects introduce pathogens like the ones that cause malaria, encephalitis, yellow fever, plague, African sleeping sickness, typhus and Rocky Mountain spotted fever, they become real medical threats.

#### 7-4. ENVENOMIZATION

Envenomization though not as bad as disease vectors still have a mortality rate that cannot be ignored. Arthropods such as bees, wasps, ants, spiders, scorpions, and centipedes either through a sting or bite can produce death. There are two types of envenomization problems. The first is a toxic effect that is when the venom of the arthropod causes the effects without any outside influences such as an allergy. Some venoms produce only slight pain and irritation while others are toxic enough to produce death. The other problem is with anaphylactic shock (a very rapid severe reaction that can cause death within a few minutes). Personnel who suspect they may have this problem should be tested. The most common arthropod to cause this effect is the honeybee, but so can wasps and ants.

| Categories of Arthropod-borne Disease                               | Immunization       | Prophylaxis | Environmental                       | Personal Protective Measures   |
|---|--------------------|-------------|-------------------------------------|--|
| Mosquito-borne<br>Malaria<br>Yellow Fever<br>Encephalitis<br>Denoue | Yellow Fever       | Malaria     | Chemical<br>Draining<br>Screening   | Repellents<br>Aerosol bomb<br>Proper wearing of uniform<br>Bednets     |
| Fly-borne (Non-biting)<br>Dysentery<br>Cholera Typhoid              | Cholera<br>Typhoid |             | Sanitation<br>Chemical<br>Screening | Aerosol bomb   |
| Fly-borne (Biting)<br>Leishmaniasis<br>Trypanosomiasis<br>African   |                    |             | Chemical                            | Repellents<br>Aerosol bomb<br>Proper wearing of uniform                |
| Flea-borne<br>Plague<br>Murine Typhus                               | Plague             |             | Chemical<br>Rodent Control          | Repellents<br>Proper wearing of uniform<br>Avoidance of infested areas |
| Tick-borne<br>Rocky Mountain spotted fever<br>Relapsing Fever       |                    |             | Chemical<br>Cut tall grass          | Repellents<br>Proper wearing of uniform                                |
| Mite-borne<br>Scrub Typhus  |                    |             |                                     | Repellents<br>Proper wearing of uniform                                |
| Louse-borne<br>Epidemic Typhus                                      | Epidemic Typhus    |             | Chemicals                           | Personal hygiene to include normal laundering of clothing              |

Table 7-1. Types of arthropod-borne disease control.

## **7-5. DERMATITIS**

Dermatitis can be a problem not with mortality but instead as a real nuisance that can be very unpleasant. Dermatitis is an inflammation or irritation of the dermal tissues (skin). Some arthropods can emit chemicals through their exoskeleton that, upon contact with our skin, can cause blisters. The most common one is the blister beetle. The irritation is actually a chemical burn that may take a week to two weeks to heal. Caterpillars may have spines or fine hairs that are attached to glands that produce chemicals to irritate their attackers. When touching them, the hairs and spines puncture the skin and inject the poison. Usually they cause pain, redness, and itching that may last for a few hours or a few days.

## **7-6. FEAR OF ARTHROPODS**

When people have an unreasoning fear of arthropods, it is called entomophobia. Some people will hurt themselves trying to get away from insects. Probably the best way to overcome this fear is by education. Once people learn what problems are associated with these arthropods and what we can do to combat them, then they can start to become less afraid of them.

## **7-7. ARTHROPODS AFFECT SENSE ORGANS**

Sometimes arthropods can cause accidental injury to us especially to our sense organs, that is., eyes and ears. Even when very small arthropods strike us in the eyes, it hurts. Depending on the size of the arthropods and speed that they are flying, they may cause blindness. When they crawl into your ears, they may have difficulty in backing out so they keep going forward and deeper and may cause temporary hearing loss or permanent ear damage. Protective measures such as goggles and earplugs will stop arthropods from damaging those organs.

## **7-8. MYIASIS**

Myiasis is a condition which maggots (fly larvae) infest a living organism. Some larvae can actually be beneficial. In an infected wound, maggots may eat only dead and decaying tissue. This would be beneficial. It would help control massive infections or gangrene by the larvae eating the decaying tissues. The larvae that might be non-beneficial would be the ones that may infiltrate our bodies and set up household under the skin. This creates a situation that would be less than desirable. This type of insect is called a botfly. When found, they should be surgically removed to prevent possible infection.

## **7-9. ALLERGIES**

Allergies can be caused by numerous types of arthropods. We have already mentioned the problems with bee stings causing death. Some of the others only cause irritation to different tissues of our bodies. For example, butterflies have a powder on their wings that if inhaled or gets into some peoples eyes causes the same symptoms one might expect with hay fever. Some insects such as beetle larvae have hairs that break off, work into the skin or mucous membranes, and cause an irritation that may be an allergic response. As mentioned before, if you suspect this problem, then you should have it checked by the allergy clinic at your installation.

## **7-10. TRANSMISSION OF DISEASES**

When diseases are transmitted from arthropods to man or animals, it is done by one of two methods. The arthropod has to transmit the pathogen from itself to us either through mechanical or biological contamination.

a. In mechanical transmission, the arthropod (for example, fly or cockroach) picks up the pathogen on its skin or mouthparts from a contaminated source, then land on our food or water source and deposits them. We then ingest the food or water and contact the disease organism. The best way of handling this problem is to keep the arthropods from our food and water sources, also control the contaminated sources well enough to stop the arthropods from breeding there. This is basic sanitation.

b. In biological transmission, the pathogen is actually carried around inside the arthropod until transmission occurs. The most effective way is inoculation. The pathogen passes through the mouthparts of the arthropod to the victim during the feeding process of the arthropod. This would give you much the same effect as if you were to give yourself a shot or immunization. Mosquitoes, ticks, mites, and fleas are very efficient with this method.

## **7-11. ARTHROPOD REGURGITATION**

Regurgitation works with arthropods that have to premoisten their food before they can eat it, such as flies. They literally throw up on your food then you eat it. When they deposit that vomitus on your food, they leave the pathogens for you to ingest.

## **7-12. FECAL CONTAMINATION**

Fecal contamination is just that. Arthropods defecate on food, water, or eating surfaces in a way that we come into contact with it. This action, just like regurgitation, can introduce pathogens to us.

### **7-13. HEALTH CARE**

Crushing the vectors between our fingers, then putting them (fingers) in our mouth can cause pathogenic organisms to be introduced into our system. Also, rubbing our eyes or picking our nose can accomplish the same thing. Be careful when swatting flies and mosquitoes.

### **7-14. VECTORS**

When discussing arthropods as disease vectors, we are going to try to match the vector (arthropod) with the disease. In looking at this, we can see the vectors, their diseases, and what we can do to defend ourselves. Notice the immunizations available along with the chemoprophylaxis. Environmental control measures available should be noted and particular attention should be paid to the personal protective measures.

### **7-15. LEVELS OF RESPONSIBILITIES**

Everyone in the Army is familiar with the chain of command. In preventive medicine, there are different levels of responsibilities for arthropod and rodent control.

### **7-16. INDIVIDUAL LEVEL**

The first level and most important is the individual level or personal protective measures. This is when the individual soldier, that is, private, sergeant, captain or colonel, has to know how to protect himself from the arthropod threat. The individual should wear the uniform properly ensuring a minimal amount of exposed skin, that is, sleeves rolled down and all buttons buttoned. The use of repellents is very important. This will stop biting insects because it tastes bad. Repellents should be placed on exposed skin and any clothing that pulls tight to the skin. Bed nets should be used at night to prevent insect bites during sleep. In conjunction with bednets, aerosol bombs should be used. Aerosol should be sprayed seven second for each one thousand cubic feet of air space. This works very well for small flying insects, that is., mosquitoes, flies, and sand flies.

### **7-17. FIELD SANITATION TEAM**

The field sanitation team (FST) helps company commanders maintain control of arthropods. The FST's primary job is to advise the commander of potential health problems. AR 40-5 requires each company-sized unit to have an FST. Two personnel are assigned on orders to this team--one NCO and one junior enlisted. They will be trained by preventive medicine personnel to recognize potential health problems and the steps to reduce that problem. Arthropod control at the unit level would consist primarily of preventive steps, that is, sanitation, screening, latrine closing, and education of the troops. When necessary, some arthropod control measures are available, but

control equipment is limited. Some things available are the two-gallon sprayer with 1 percent Baygon insecticide, aerosol bomb, Lindane dust, rodent traps, and fly swatters. Remember that this is to assist the commander to maintain control of arthropod problems; if the commander cannot, then he should call for help to the next level, which is the preventive medicine unit, for his area.

## **7-18. FIELD ENVIRONMENTAL CONTROL**

The LA Team is a preventive medicine team designated to survey and control arthropods and train troops in the field environment. There are five officers and 35 enlisted men assigned to this unit. They are preventive medicine personnel that aid the commanders. When the commander feels the arthropod problem is beyond his control, he calls this unit to help. The LA Team will survey the problem and perform any control measures necessary. Another important job of the LA Team is to train troops in preventive medicine. Some of the equipment available to the LA Team is hydraulic sprayer, power delouser, and FST equipment, and various types of pesticides.

## **7-19. INSTALLATION LEVEL**

At the post or installation level (not field), there is a Preventive Medicine activity assigned to the Hospital. Their job is preventive medicine on permanent facilities and personnel assigned to that facility. The primary concern of this activity for entomological problems would be to survey for arthropods and then make recommendations to the appropriate activity to control them. Most of the surveys are conducted during routine sanitation inspections of various facilities, for example, dining halls, barracks, post exchange (PX), commissary, and hospitals. The control measures are recommended to the Directorate of Facilities (CE) Engineers on permanent installations.

## **7-20. CONTROL RESOURCES**

When the commander has an arthropod problem, his resources should be first the FST, then the LA Team; if in the field or the MEDDAC the preventive medicine activity. Once the PM activity has surveyed and recommended control measures, the commander should then call the facilities engineers to perform the control measures. The engineers are responsible for control of arthropods at fixed installations in dining halls, barracks, government quarters, PX, commissary, and hospitals. They are responsible for land management, forestry, and wildlife management. Engineers are DA Civilians and, sometimes, private companies hired to perform special jobs. The engineers operate under the guidelines of preventive medicine and the Office of The Surgeon General. The equipment used is whatever is necessary to control pest problems (ULD and ULV sprayers, hydraulic sprayers, buffalo turbine sprayers, and so forth) with the pesticides used with these pieces of equipment.

**Continue with Exercises**

## EXERCISES, LESSON 7

**INSTRUCTIONS.** The following exercises are to be answered by marking the lettered response that best answers the question or best completes the incomplete statement or by writing the answer in the space provided.

After you have completed all the exercises, turn to "Solution to Exercises" at the end of the lesson and check your answers.

1. When considering military entomology, which is (are) significant?
  - a. World-wide commitments.
  - b. Guerrilla-type warfare.
  - c. Susceptible population.
  - d. All of the above.
  
2. The most important way arthropods affect our health is:
  - a. Dermatitis.
  - b. Entomophobia.
  - c. Bites.
  - d. Myiasis.
  
3. Myiasis is:
  - a. A disease transmitted by ticks.
  - b. An infestation of fly larvae.
  - c. A form of biological contamination.
  - d. A form of mechanical contamination.

4. Rocky Mountain Spotted Fever (RMSF) is transmitted by which vector?
  - a. Mosquito.
  - b. Tick.
  - c. Flea.
  - d. Louse.
  
5. Malaria and Yellow Fever are transmitted by which vector?
  - a. Tick.
  - b. Flea.
  - c. Crab louse.
  - d. Mosquitoes.
  
6. Dysentery (that is, cholera) is transmitted by:
  - a. Mosquitoes.
  - b. Frogs.
  - c. Filth flies.
  - d. Ticks.
  
7. The Field Sanitation Team is required at which level?
  - a. Post Headquarters.
  - b. Company or equivalent-size unit.
  - c. Brigade level.
  - d. Division level.



8. The LA Team does what types of surveys?
  - a. Sanitation.
  - b. Industrial hygiene.
  - c. Tuberculosis surveys.
  - d. Arthropod and rodent.

**Check Your Answers on Next Page**

## **SOLUTIONS TO EXERCISES, LESSON 7**

1. d para (7-2)
2. c para (7-3)
3. b para (7-8)
4. b (Table 1-7)
5. b (Table 1-7)
6. c (Table 1-7)
7. b para (7-17)
8. d para (7-18)

**End of Lesson 7**

## LESSON ASSIGNMENT

### LESSON 8

Sexually Transmitted Diseases.

### LESSON ASSIGNMENT

Paragraphs 8-1 through 8-14.

### LESSON OBJECTIVES

After completing this lesson, you should be able to:

- 8-1. Identify the correct signs, symptoms, and epidemiologic features about gonorrhea and syphilis.
- 8-2. Identify public opinions against sexually transmitted diseases.
- 8-3. Identify the methods of prevention and control of sexually transmitted diseases.

### SUGGESTION

After completing the assignment, complete the exercises at the end of this lesson. These exercises will help you to achieve the lesson objectives.

## LESSON 8

### SEXUALLY TRANSMITTED DISEASES

#### Section I. THE ARMY'S SEXUALLY TRANSMITTED DISEASE CONTROL PROGRAM

##### 8-1. HISTORY

a. Prior to 1900, little attention was paid to diseases in the Army, except for the professional care given to infected personnel and sporadic efforts at control. In the period 1900-1912, The Surgeon General forced attention to the fact that sexually transmitted disease was a serious problem and a real threat to the health and efficiency of the Army. Influenced by the early work of Schaudinn and Erlich on the diagnosis and treatment of syphilis, he initiated scientific studies on chemicals in the hope of finding a chemical prophylactic against syphilis and gonorrhea. During this period also, the Congress became interested in the sexually transmitted disease problem of the Armed Forces and passed punitive legislation aimed at the soldier or sailor who became noneffective because of this disease. These infections were declared to be "due to misconduct" and the offender was punished by loss of his pay and was forced to make up time lost for this reason at the end of his enlistment. (In 1912, prophylaxis for all personnel who exposed themselves to sexually transmitted disease was made compulsory, and unannounced semimonthly physical ("short arm") inspections of all enlisted men were introduced.) During the ensuing 30 years, chemical and mechanical prophylaxis combined with punishment in some form or other, constituted the main elements of the sexually transmitted disease programs of the Army and Navy. However, the experience of World War I had led to the realization that commanding officers of all grades could exert a marked influence upon the off-duty activities of their men if they took an active interest in their welfare. As a result, the Army Regulations on sexually transmitted disease control published in 1923 emphasized the responsibility of the commanding officer to the extent that the sexually transmitted disease rate of an organization was to be considered a measure of the efficiency of the commander.

b. During the latter part of the 1930s, under the influence of a campaign sponsored by the US Public Health Service to bring the problem into the open, it became increasingly clear that legislating sexually transmitted disease and sexual promiscuity into oblivion, while theoretically possible, was in practice utterly impossible. The thinking in the Army gradually shifted around to the point of view that the sexually transmitted diseases, being infectious states, should be looked upon as any other infectious disease problem and treated accordingly. Particular concern was expressed over the possibility that the punitive measures used in the Armed Forces were conducive to concealment and were resulting in poor and inadequate treatment of many cases. This opinion gained strong support among civilian public health authorities and the Armed Forces and, as a result, the four years of World War II saw a

step-by-step elimination of the old punitive measures, until by 1944, there remained only the provision that a soldier could be punished for willfully concealing a venereal infection. This is the only punitive measure authorized at present.

c. In line with changing attitudes of military and civilian leaders, the Army began in 1946 to de-emphasize prophylaxis as a control measure and to emphasize the moral and spiritual approach to the problem. In 1947, the Chief of Staff stated that the control of sexually transmitted disease was a responsibility of the commanding officer and that the technical staff officers (surgeons, provost marshals, chaplains, and so forth) would be utilized only as technical advisors in their special fields. Thus, the Army's program of sexually transmitted disease control became for the first time in a real sense, a command program of prevention rather than punishment or after-the-fact medical treatment.

## **8-2. PUBLIC ATTITUDE TOWARD SEXUALLY TRANSMITTED DISEASE**

The prevalence of sexually transmitted diseases is dependent upon the availability of infected persons and the frequency and range of exposure. Unlike most other communicable diseases, venereal disease (VD) for many years has flourished simply because a false modesty has kept people from the words "syphilis," "gonorrhea," and "venereal disease" in public. So great was the name attached to these diseases that many doctors often hesitated to treat them, fearing possible injury to their professional prestige. Currently VD is a complex problem having both medical and sociological overtones that are inseparable.

## **Section II. THE EPIDEMIOLOGY OF SEXUALLY TRANSMITTED DISEASES**

### **8-3. MODE OF TRANSMISSION**

a. Sexually transmitted diseases are spread from person to person almost<sup>1</sup> entirely by sexual contact. The chances of becoming infected increase tremendously when an individual changes sexual partners frequently. Some individuals who feel guilty of promiscuous sexual relations and want to hide their sexual escapades often blame objects such as toilet seats, towels, personal articles, and dishes as vehicles of infection. Venereal disease agents cannot live long away from the human body and, except for remote possibilities, sexually transmitted disease is not transmitted in such a manner.

---

<sup>1</sup> Nurses, doctors, and laboratory technicians rarely have become accidentally infected through coming in contact with syphilitic infections when examining or treating VD patients or when handling laboratory specimens. Gonorrhea has been transmitted from person to person, usually young children, in hospitals by rectal thermometers which have been improperly sterilized after use. Newborn babies born of infected mothers may acquire gonococcal infection in the conjunctiva of the eyes if proper care (normally eye drops of 1 percent silver nitrate solution) is not afforded at childbirth.

b. Although some sexually transmitted disease is acquired through sexual exposure with casual acquaintances and "pickups", most cases are contracted by continued contact with a regular sexual partner. The importance of promiscuity cannot be overemphasized, however, since two noninfected persons cannot possibly transmit disease to one another. At least a third person must always be involved.

c. Prostitutes are a minor source of sexually transmitted disease in the US; however, they are always a potential source of infection. Their constant repeated contacts make it virtually impossible for them to remain free of infection indefinitely. It is possible for a man to acquire infection from a prostitute infected only a few minutes before.

#### **8-4. GONORRHEA**

a. **General.** Gonorrhea accounts for the majority of sexually transmitted disease among military personnel; it is caused by a bacterium, *Neisseria gonorrhoea*, also known as the gonococcus. The incubation period is from 2 to 14 days, with an average of 3 to 5 days. The symptoms are a yellow discharge from the penis in the male (may be only mucoid at first) and from the vernix and/or urethra in the female, with burning and urinary frequency. In the female, the infection may not be noticeable. The discharge may be prolonged without treatment or with improper treatment. Diagnosis is made by microscopic examinations of smears and cultures. Untreated or improperly treated gonorrhea may result in severe complications involving other parts of the body. Arthritis and sterility may occur. In rare instances, heart disease or septicemia complicates the disease and may end fatally. The disease is infectious as long as gonococci are harbored in the prostate, cervical, or other genital glands.

b. **Treatment.** All patients to be treated for gonorrhea should have a serologic test for syphilis (STS) prior to receiving specific treatment for gonorrhea and a repeat STS monthly for 3 months following such treatment. Patients should be cautioned to report to a medical officer promptly if lesions suspicious of primary or secondary syphilis develop. Treatment of male patients with typical clinical symptoms of gonorrhea need not be delayed until laboratory confirmation of the diagnosis is obtained; however, several unstained films of the discharge should be prepared before treatment for later study. In females, cultures of the urethral or cervical discharge should also be made. A case of uncomplicated gonorrheal urethritis should be treated on a duty status as an outpatient. Individuals with complications should be hospitalized immediately and treatment stated.

c. **Penicillinase-Producing *Neisseria Gonorrhoea*.** Penicillinase-producing *Neisseria Gonorrhoea* (PPNG), an increasing number of gonococcal infections are resistant to the standard treatment of penicillin. These infections do not respond to treatment with penicillin and require treatment with other antibiotics. PPNG is a serious problem because it complicates the course of treatment and limits the number of drugs available to control gonorrhea. One factor that led to the development of PPNG was the use of oral antibiotic prophylaxis (no sweat pills) for prevention of gonorrhea.

## 8-5. SYPHILIS

a. **General.** Syphilis is caused by a spirochete, Treponema palladium, untreated or inadequately treated, it will usually be manifest in three stages; primary, secondary, and late, which may overlap or be absent altogether.

b. **Primary Syphilis.** The incubation period for primary syphilis is variable (10 to 90 days, with 3 weeks being usual). The first indication of primary or early syphilis is an open sore, known as a chancre, which appears at the site of entrance of the spirochete. The chancre may persist for from 1 to 5 weeks and heal without treatment. Diagnosis is made at this stage by finding the spirochete in darkfield microscopic examination of material taken from the chancre. If the chancre has only recently developed, the blood test for syphilis will be negative at this time. The appearance of the chancre is often not typical and cannot be relied upon as a positive diagnosis. In some cases, the chancre may be so insignificant that it goes undetected. All patients with genital lesions of any type should be suspected of having syphilis and should have repeated darkfield examinations and serological tests in order to confirm or rule out this possibility. Lesions of the lips, fingers, female breasts, or occasionally elsewhere on the body, which fail to heal within 10 days, should be inspected as extragenital primary syphilis and warrant repeated darkfield examinations.

c. **Secondary Syphilis.** Secondary lesions of early syphilis may appear in the form of a skin eruption, accompanied by enlarged lymph glands, within a period of from 3 to 8 weeks or longer after appearance of the initial lesion. In addition or separately, there may also be one or more of a large variety of symptoms that include lesions in the mouth, and genitalia, condylomata (moist, flat top papules), sore throat, patchy falling of hair, headache, malaise and fever. These secondary lesions usually disappear within about 3 weeks. If untreated, they may reappear one or more times as relapses. Diagnosis may be made from early lesions by darkfield examinations, but these may be negative during the secondary stage. The serological test for syphilis (SYS) is almost always positive during this stage.

d. **Late Syphilis.** Late syphilis follows secondary syphilis after a period of latency of from 5 to 20 years. Complications of this stage may be blindness, insanity, paralysis, vascular disease, loss of position sense, arthritis, or granulomas in any organ or tissue of the body. Darkfield examinations of any lesions in this stage are almost always negative; blood test is usually positive but may be doubtful or negative. The longer the duration, the greater likelihood that the serological tests will become negative spontaneously. The spinal fluid examination may or may not be positive. If it is positive, the patient has central nervous system syphilis. This may go on for years before symptoms develop. Some patients, however, may have symptoms of central nervous system syphilis without positive spinal fluid findings.

e. **Treatment of Primary and Secondary Syphilis.** Penicillin is the treatment of choice in these stages of infection. Treatment of these patients can usually be carried out in a duty status. Favorable results may be anticipated in over 90 percent of the cases discovered and treated in the primary state and in 75 to 85 percent of those treated in the secondary stage.

## **8-6. HERPES PROGENITALIS**

a. Genital herpes is a sexually transmitted disease caused by the herpes virus. Although the disease has been recognized for many years, physicians have noted a great increase in the number of cases seen. Some epidemiologists believe that genital herpes may be as common as gonorrhea.

b. Herpes usually begins as a crop of small red patches on the outside of the genitalia. These form tiny blisters which eventually slough off and form ulcers. These blisters and ulcers will cause pain on urination and a burning sensation. These painful lesions disappear within a week, but may reappear at any time, usually when the individual is undergoing some sort of stress. Herpes is transmitted by direct contact with the lesions. Herpes infections are not necessarily sexually transmitted.

c. Presently there is no cure for genital herpes. Treatment consists of soothing ointments. Antiviral drugs inhibit replication of herpes simplex viruses and when applied topically may decrease viral shedding. Genital herpes can be prevented by avoiding contact with active lesions. The use of a condom will substantially reduce the risk of transmission. No intercourse should be permitted when lesions are active.

## **Section III. OTHER SEXUALLY TRANSMITTED DISEASES**

### **8-7. CHANCROID**

One of the less common venereal diseases is chancroid (chancre-like). Chancroid is characterized by a local rapidly developing, pus-filled vesicle which ruptures and becomes multiple, painful, dirty sores. It is caused by the Ducrey bacillus (Hemophilus ducrey) and is diagnosed by direct microscopic examination of stained smears from the lesion, or by cultures. The incubation period is short, being from 3 to 5 days. The lesions are very painful and are accompanied by a painful and tender swelling of the regional lymph nodes in about 50 percent of the cases. Almost any portion of the genitalia and perineum may be involved.

### **8-8. LYMPHOGRANULOMA VENEREUM**

Lymphogranuloma venereum is a systemic virus disease which sometimes starts with a small transitory primary sore on or around the genitalia. It is a disease of the lymph nodes and channels primarily and usually shows bubo formation and sometimes ulceration. In neglected cases, it may cause rectal stricture and great swelling of the testicles. The incubation period varies from 5 to 21 days.



## **8-9. GRANULOMA INGUINALE**

Granuloma inguinale is a chronic ulcerative disease of the skin and mucous membranes caused by a bacterium, *Donovania granulomatis* (Donovan bodies). The diagnosis is established by demonstration of the causative agent in smears. This disease begins with a small pimple or painless ulcer after an incubation period of from 1 to 12 weeks. It starts as a vesicle, papule, or nodule which develops and spreads by continuity (daughter lesion developing near larger lesions) and may involve several structures of the male or female groin areas. This disease may last for years, during which it produces chronic beefy-red, ulcerating lesions. In some instances, general ill health and death may result.

## **8-10. ARMED FORCES DISCIPLINARY CONTROL BOARDS**

The activities of the Armed Forces Disciplinary Control Board are aimed toward the elimination of conditions inimical to the health, morale, and welfare of Armed Forces personnel, and for ensuring the establishment and maintenance of the highest degree of liaison and coordination between military commands and civil authorities. At least one Armed Forces Disciplinary Control Board is established in each of the larger area jurisdictions of the Armed Services. Each board is composed of the senior disciplinary and medical representatives of the US Army, US Navy, US Air Force (USAF), and Coast Guard commanders in the area. Subordinate boards may be established with limited geographical jurisdiction. The board meets at least once a month to inform itself and receive and consider reports on conditions in the area of its jurisdiction relating to improper discipline, prostitution, homosexual activity, sexually transmitted disease, liquor violations, disorder, and other undesirable conditions as they apply to service personnel. The board usually invites representatives of interested civilian law enforcement, health, and liquor control agencies to participate in the meetings, along with representatives of the American Social Health Association, the US Brewers Association, associations of hotel owners, tavern operators, and the like. Undesirable conditions can usually be eliminated or improved by joint action of the various agencies represented or in conjunction with the owners and operators of offending establishments. In the event such joint action fails, the board reports the condition and its recommendations to the respective Armed Forces commanders. This report will often take the form of a recommendation of "off limits" action against a designated place, after appropriate warning to the proprietor thereof. This will normally result in the publication of an "off limits" order applicable to all personnel of the Armed Services and jointly enforced. This system of consultation and orderly application of the commander's authority initiated during World War II has greatly increased the effectiveness of disciplinary control in extra military areas.

## **8-11. CONTROL OF PROSTITUTION**

The difficulty in controlling sexually transmitted disease is further compounded in a community where a large number of prostitutes operate. Therefore, the policy of the Department of the Army is to cooperate fully with civilian authorities in the repression of prostitution. Since military authorities have no jurisdiction over civilians, commanders and military police must assist civilian law enforcement agencies in the repression of prostitution by strictly enforcing "off limits" directives and by providing information concerning known prostitutes.

## **8-12. ARMY HUMAN SELF-DEVELOPMENT PROGRAM**

The purpose of the Army human self development program is to assist the commander in promoting healthy mental, moral, and social attitudes in the personnel under his command. Under this program, the Army undertakes to ensure, insofar as is possible under the conditions of military service, the continuance of the wholesome influence of the home, the family and the community. The program is broad in its applications, positive in its approach, and embraces all activities of the soldier.

## **8-13. EDUCATION AND MANAGEMENT OF SUSCEPTIBLES, SUSPECTS, AND CASES**

a. **General.** Most young soldiers do not expose themselves to sexually transmitted diseases. They do not desire to contract an infection and will make the necessary effort to avoid it because of personal moral standards. Occasionally, however, such an individual may contract an STD. In such an instance, individual concern usually prevents repetition. These soldiers usually will cooperate willingly in helping to bring sex partners to treatment. To attempt to prevent reinfection in such individuals by the use of fear, punishment, or disgrace is needless and is, in the long run, harmful in its effect upon the morale of personnel. Guidance and advice are more effective than fear of punitive action for the majority of servicemen. A fairly large number of cases of sexually transmitted disease in military personnel occurs in a small minority of unmanageable individuals who repeatedly contract infection. These individuals usually are socially maladjusted in other ways and would behave the same in or out of the military service. To resort to control methods involving fear of punishment or social disrepute has little, if any, effect on these individuals. They are best eliminated from the service because of their basic maladjustment, not because they have contracted an STD. Moreover, personnel in the service must not be permitted to believe that such individuals were discharged for sexually transmitted disease infection, because this belief is likely to encourage concealment of the disease out of fear of being discharged as undesirables.

## **b. Command and Staff Efforts.**

(1) Guidance versus force. Present day methods of treatment have eliminated most of the time lost due to STD. Yet, STD continues to command a disproportionate interest on the part of individuals because of the implication of wrongdoing which accompanies it. As such, it should be dealt with by concerted attempts to foster attitudes and promote activities which tend to discourage sexual promiscuity. These efforts require the interest and combined participation of various individuals, including commanders, medical officers, chaplains, and special services personnel. Success in the prevention of sexually transmitted disease requires coordinated and continuous effort applied in an intelligent, unbiased, and understanding manner by each commander and his staff. The control of STD will be accomplished by intelligent leadership, not by misdirected force.

(2) Abuse of oral penicillin prophylaxis. The prophylactic use of penicillin is not medically effective against gonorrhea, may encourage the development of increasingly resistant strains. It may also mask the early symptoms of syphilis. Therefore, it is not looked upon as a desirable means for the prevention of sexually transmitted disease.

(3) Use of physical inspections. Physical inspection of personnel is not conducted on a regular basis, but only when ordered by commanders upon medical advice; for example, if there is reason to suspect that individuals are concealing infections. Physical inspection must be unannounced to be effective in discovering gonorrheal infection. All personnel for whom the inspection is intended must be included.

(4) Use of sexually transmitted disease statistics. In order to keep the responsible commander informed concerning the amount of STD in his command, the surgeon or director of medical activities maintains certain monthly statistical data to include the number of new cases of gonorrhea, syphilis, and other sexually transmitted diseases, as well as the STD rate per 1,000 per month. These data are included in the command health report. Great care must be exercised in the use of STD statistics. The release of STD information when it may be misused, such as to compile indices of unit morale or commander efficiency, must be avoided. The reporting of individual names outside of medical channels is prohibited, as this information can be misused to identify individuals for direct or indirect punishment. This would result in the failure of individuals to report infections and thus compromise the sexually transmitted disease control program.

**c. Continence and Promiscuity.** Continence--the total abstention from sexual contact--is the only certain means for the avoidance of STD. The enforcement of continence is not practical; however, promiscuity should be discouraged both from a moral and health standpoint. If every person indulging in sexual relations would confine these relations to one partner, any sexually transmitted disease that might be present could normally be kept within the family and eliminated with treatment.

d. **Personal Hygiene.** Despite the emphasis which may be placed on the moral aspects of sexual conduct, it is virtually impossible to legislate morality. Many soldiers are completely unreceptive to the concept of abstinence or to restricting their sexual relations to one person. Therefore, the only way to reach these individuals is a STD prevention program is through education in personal hygiene measures. The condom, if used properly, affords effective protection against STD. However, it is not always used properly, if at all. Soldiers should be taught that urinating and thorough washing of the genitalia soon after intercourse will afford protection to some degree. The combined use of the condom and personal hygiene should be emphasized and encouraged.

e. **Contact Tracing.** One of the most effective public health measures against sexually transmitted disease is tracing sources and contacts of known cases and bringing them under treatment. The commander of the medical treatment facility where the disease is diagnosed is responsible for promptly obtaining complete identifying information concerning all individuals with whom an STD patient may have had an infectious contact.

(1) Interviewing. A patient whose illness is diagnosed as a sexually transmitted disease is interviewed by a trained venereal disease contact interviewer and urged to provide information about those persons from whom he could possibly have contracted the disease and persons with whom he has had sexual contact since becoming infected. In the interview, he is apprised of the nature of his infection, the manner in which it is transmitted, and the necessity for his cooperation in the curtailment of the disease.

(2) Contact reporting. When a patient reports a civilian contact, a separate report, on each contact is transmitted to the health officer of the state in which the contact resides or is presumed to reside. Speed is essential in the tracing of contacts because of the manner in which STD spreads, therefore, it is incumbent upon the medical officer acting for the commander to assure prompt initiation and transmission of the Venereal Disease Epidemiologic Report. This report constitutes a medical record of a privileged nature and the source of the information (patient) is not identified on the forms submitted. Following the investigation and disposition of the contact, the civilian health agency reports its findings to the originating installation through the Army area surgeon.

(3) Receiving contact reports. Reports received from civilian health agencies of alleged contacts among Army personnel or employees are investigated, and indicated examinations and treatment are performed. The reporting agency is informed of the action taken as appropriate.

## 8-14. ROLE OF THE ARMY MEDICAL DEPARTMENT

Under current policies, the role of the Army Medical Department may be summarized as follows:

- a. Treating the infected individual.
- b. Conducting research aimed at improving curative and prophylactic techniques.
- c. Keeping the commander informed on the rates and trends of sexually transmitted infections in the command.
- d. Interviewing sexually transmitted disease cases and reporting of contacts to civil health authorities.
- e. Coordinating medical instructions covering sexually transmitted diseases with the chaplain's instruction in sex morality.
- f. Furnishing scientific instruction in sex hygiene to include:
  - (1) Names and characteristics of the various sexually transmitted diseases.
  - (2) Manner of transmission of sexually transmitted diseases, and the dangers of promiscuous sexual relations.
  - (3) Methods of prevention, stressing continence as the only certain prophylaxis against sexually transmitted disease.
  - (4) Fundamental requirements of good treatment; the dangers of neglect, self-treatment, and improper treatment; the limitations of modern methods of treatment; and the nature and long-range significance of complications.

**Continue with Exercises**

## EXERCISES, LESSON 8

**INSTRUCTIONS.** The following exercises are to be answered by marking the lettered response that best answers the question or best completes the incomplete statement or by writing the answer in the space provided.

After you have completed all the exercises, turn to "Solutions to Exercises" at the end of the lesson and check your answers.

1. The venereal disease of the highest reported incidence is:
  - a. Syphilis.
  - b. Gonorrhea.
  - c. Chancroid.
  - d. Lymphogranuloma venereum.
  
2. For which of these diseases is a chancre an early sign?
  - a. Gonorrhea.
  - b. Granuloma inguinale.
  - c. Lymphogranuloma venereum.
  - d. Syphilis.
  
3. Approximately, what are the chances that specific treatment given any soldier for his primary syphilis infection will be successful?
  - a. 10 percent.
  - b. 50 percent.
  - c. 75 to 85 percent.
  - d. 90 to 100 percent.

4. If a primary syphilis lesion disappears without treatment, what can the patient logically assume?
  - a. That he has had a spontaneous cure.
  - b. That he will be immune from further infection.
  - c. That more serious symptoms may be expected.
  - d. That he will probably die within a year.
  
5. Usually, the most prominent sign of secondary syphilis is:
  - a. Painful, swollen gonads.
  - b. A rash or generalized skin eruption.
  - c. Beefy red, granular sores.
  - d. A more or less constant purulent discharge from the genitals.
  
6. A creamy yellow discharge from the male urethra is an early sign of:
  - a. Gonorrhea.
  - b. Granuloma inguinale.
  - c. Lymphogranuloma venereum.
  - d. Syphilis.
  
7. Probably the most painful of the venereal diseases in the early stage of infection is:
  - a. Chancroid.
  - b. Granuloma inguinale.
  - c. Lymphogranuloma venereum.
  - d. Syphilis.

8. Gonorrhea is frequently unnoticed in \_\_\_\_\_.
9. For which of these acts is a soldier subject to punitive measures?
- Contracting VD.
  - Willfully concealing a venereal infection.
  - Giving sex information to recruits.
  - All of the choices above.
10. Which venereal disease, if untreated over a long period of time, may result in enlarged, swollen testicles?
- \_\_\_\_\_.
11. Malaise, sore throat and patchy bald spots may be symptoms of:
- All of the following.
  - Primary syphilis.
  - Secondary syphilis.
  - Gonorrhea.
  - Granuloma inguinale.
12. Which of the following is purposefully omitted from a completed Venereal Disease Epidemiological Report?
- Interviewer's name.
  - Contact's sex.
  - Patient's name.
  - Patient's VD.



13. Armed Forces Disciplinary Control Boards are set up primarily to:
- Ensure that offenders in the various services receive corresponding punishment for like offenses.
  - Inform themselves about undesirable conditions and recommend joint action for correction.
  - Locate and treat infected prostitutes.
  - Act as preliminary trial courts in their areas.
14. Statistics regarding VD in a division are kept by the division surgeon for the primary purpose of:
- Furnishing information and guidance to divisional organizations.
  - Compiling reports to higher headquarters.
  - Furnishing the medical supply officer a basis for requisitioning medicaments.
  - Compiling evidence to be used at Armed Forces Disciplinary Control Board meetings.
15. One of the most effective methods of public health venereal disease control is \_\_\_\_\_
16. The only certain means of avoiding venereal disease is:
- Use of a condom.
  - Restricting sexual contact to a marital partner.
  - Total abstention from sexual contact.
  - Use of antibiotic prophylaxis.
  - Engaging in sexual intercourse frequently enough to acquire natural immunity.

**Check Your Answers on Next Page**

## **SOLUTIONS TO EXERCISES, LESSON 8**

1. b (para 8-4a)
2. d (para 8-5b)
3. d (para 8-5e)
4. c (para 8-5c)
5. b (para 8-5c)
6. a (para 8-4a)
7. a (para 8-7)
8. females (para 8-4a)
9. b (para 8-1b)
10. Lymphogranuloma venereum (para 8-8)
11. c (para 8-5c)
12. c (para 8-13e(2))
13. b (para 8-10)
14. a (para 8-13b(4))
15. contact tracing (para 8-13e)
16. c (para 8-13c)

**End of Lesson 8**